

Melting Kettles

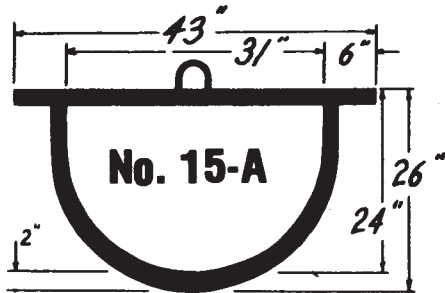

FURNISHED WITH SETTING HOOKS

12,827 CUBIC INCHES CAPACITY — BRIMFULL
APPROXIMATE WEIGHT OF KETTLE (2" DPR) 1370 LBS.

CAPACITY	ALUMINUM	1240 LBS.
	DIE CAST	3078 LBS.
	ZINC	3240 LBS.
	LEAD	5266 LBS.

SETTING RING — 35 $\frac{1}{4}$ " I.D., 62" O.D., 1 $\frac{1}{4}$ " THICK
SETTING RING — 35 $\frac{1}{4}$ " I.D., 56" O.D., 1 $\frac{1}{4}$ " THICK

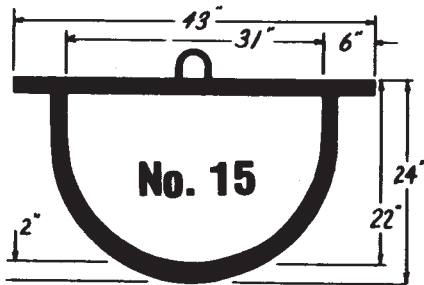

FURNISHED WITH SETTING HOOKS

11,319 CUBIC INCHES CAPACITY — BRIMFULL
APPROXIMATE WEIGHT OF KETTLE 1280 LBS.

CAPACITY	ALUMINUM	1090 LBS.
	DIE CAST	2716 LBS.
	ZINC	2859 LBS.
	LEAD	4647 LBS.

SETTING RING — 35 $\frac{1}{4}$ " I.D., 62" O.D., 1 $\frac{1}{4}$ " THICK
SETTING RING — 35 $\frac{1}{4}$ " I.D., 56" O.D., 1 $\frac{1}{4}$ " THICK

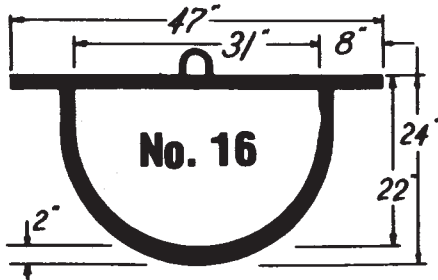

FURNISHED WITH SETTING HOOKS

APPROXIMATE WEIGHT OF KETTLE 1495 LBS.

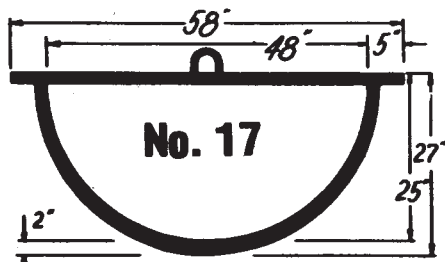

FURNISHED WITH SETTING HOOKS

28,182 CUBIC INCHES CAPACITY — BRIMFULL
APPROXIMATE WEIGHT OF KETTLE 2440 LBS.

CAPACITY	ALUMINUM	2713 LBS.
	DIE CAST	6763 LBS.
	ZINC	7118 LBS.
	LEAD	11,571 LBS.

SETTING RING — 52" I.D., 67" O.D., 1 $\frac{1}{4}$ " THICK
SETTING RING — 52" I.D., 64" O.D., 1 $\frac{1}{4}$ " THICK

WITH SPOUT 2,520 LBS.

Melting Kettles

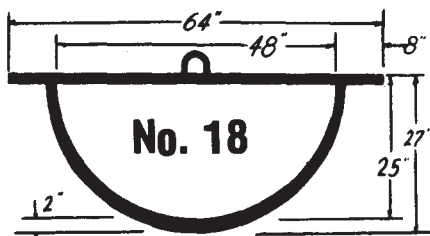

28,182 CUBIC INCHES CAPACITY — BRIMFULL
 APPROXIMATE WEIGHT OF KETTLE 2875 LBS.

CAPACITY	ALUMINUM	2713 LBS.
	DIE CAST	6763 LBS.
	ZINC	7118 LBS.
	LEAD	11,571 LBS.

SETTING RING — 52" I.D., 67" O.D., 1 1/4" THICK
 SETTING RING — 52" I.D., 64" O.D., 1 1/4" THICK

FURNISHED WITH SETTING HOOKS

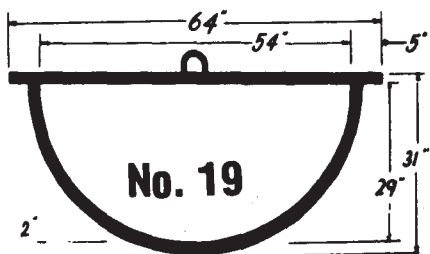

41,580 CUBIC INCHES CAPACITY — BRIMFULL
 APPROXIMATE WEIGHT OF KETTLE 2985 LBS.

CAPACITY	ALUMINUM	4004 LBS.
	DIE CAST	9979 LBS.
	ZINC	10,503 LBS.
	LEAD	17,072 LBS.

SETTING RING — 58" I.D., 74" O.D., 1 1/4" THICK
 SETTING RING — 58" I.D., 70" O.D., 1 1/4" THICK

FURNISHED WITH SETTING HOOKS

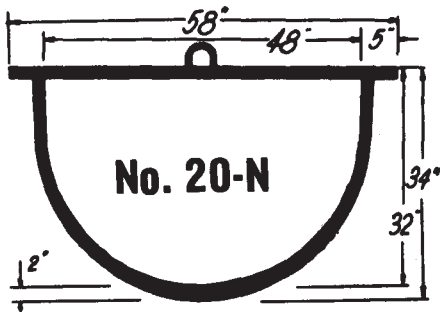

39,732 CUBIC INCHES CAPACITY — BRIMFULL
 APPROXIMATE WEIGHT OF KETTLE 3080 LBS.

CAPACITY	ALUMINUM	3826 LBS.
	DIE CAST	9535 LBS.
	ZINC	10,036 LBS.
	LEAD	16,313 LBS.

SETTING RING — 52" I.D., 67" O.D., 1 1/4" THICK

FURNISHED WITH SETTING HOOKS

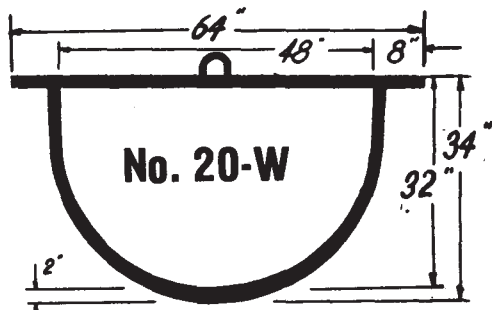

APPROXIMATE WEIGHT OF KETTLE 3140 LBS.

FURNISHED WITH SETTING HOOKS

Melting Kettles

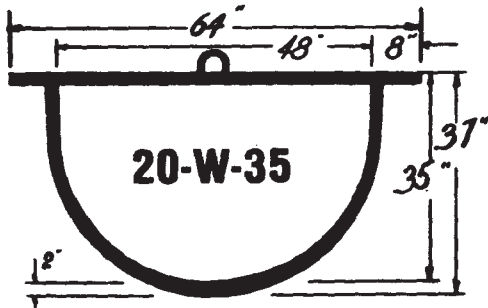

FURNISHED WITH SETTING HOOKS

39,732 CUBIC INCHES CAPACITY — BRIMFULL
 APPROXIMATE WEIGHT OF KETTLE 3,330 LBS.

CAPACITY	ALUMINUM	4,332 LBS.
	DIE CAST	10,876 LBS.
	ZINC	11,192 LBS.
	LEAD	18,548 LBS.

SETTING RING — 52" I.D., 67" O.D., 1¼" THICK

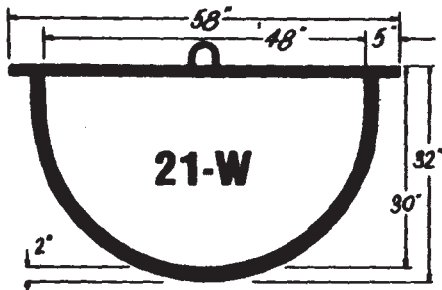

FURNISHED WITH SETTING HOOKS

36,960 CUBIC INCHES CAPACITY — BRIMFULL
 APPROXIMATE WEIGHT OF KETTLE 2850 LBS.

CAPACITY	ALUMINUM	3559 LBS.
	DIE CAST	8870 LBS.
	ZINC	9336 LBS.
	LEAD	15,175 LBS.

SETTING RING — 52" I.D., 67" O.D., 1¼" THICK

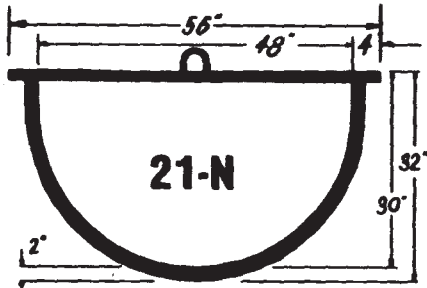

FURNISHED WITH SETTING HOOKS

APPROXIMATE WEIGHT OF KETTLE 2810 LBS.

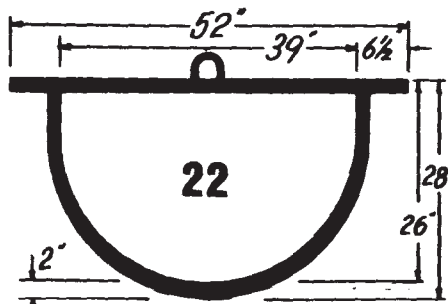

FURNISHED WITH SETTING HOOKS

22,638 CUBIC INCHES CAPACITY — BRIMFULL
 APPROXIMATE WEIGHT OF KETTLE 1860 LBS.

CAPACITY	ALUMINUM	2180 LBS.
	DIE CAST	5433 LBS.
	ZINC	5718 LBS.
	LEAD	9295 LBS.

SETTING RING — 43" I.D., 63" O.D., 1¼" THICK
 SETTING RING — 43" I.D., 55" O.D., 1¼" THICK

Melting Kettles

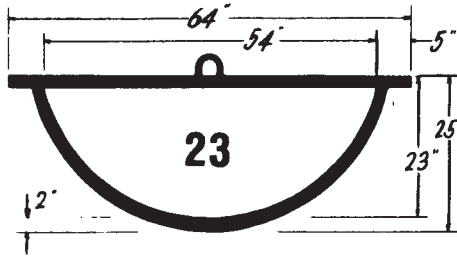

28,875 CUBIC INCHES CAPACITY — BRIMFULL
 APPROXIMATE WEIGHT OF KETTLE 2340 LBS.

CAPACITY	ALUMINUM	2780 LBS.
	DIE CAST	6930 LBS.
	ZINC	7293 LBS.
	LEAD	11,856 LBS.

SETTING RING — 58" I.D., 69" O.D., 1 1/4" THICK
 SETTING RING — 58" I.D., 74" O.D., 1 1/4" THICK

FURNISHED WITH SETTING HOOKS

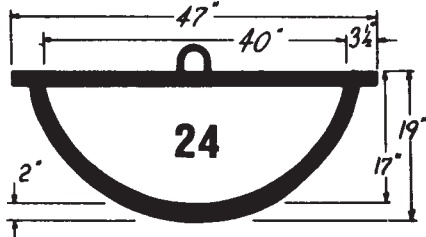

15,477 CUBIC INCHES CAPACITY — BRIMFULL
 APPROXIMATE WEIGHT OF KETTLE 1295 LBS.

CAPACITY	ALUMINUM	1490 LBS.
	DIE CAST	3714 LBS.
	ZINC	3909 LBS.
	LEAD	6354 LBS.

FURNISHED WITH SETTING HOOKS

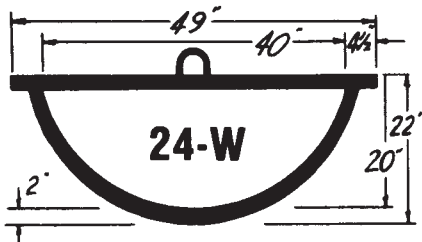

19,245 CUBIC INCHES CAPACITY — BRIMFULL
 APPROXIMATE WEIGHT OF KETTLE 1497 LBS.

CAPACITY	ALUMINUM	1852 LBS.
	DIE CAST	4618 LBS.
	ZINC	4860 LBS.
	LEAD	7898 LBS.

SETTING RING — 44" I.D., 54" O.D., 1 1/4" THICK

FURNISHED WITH SETTING HOOKS

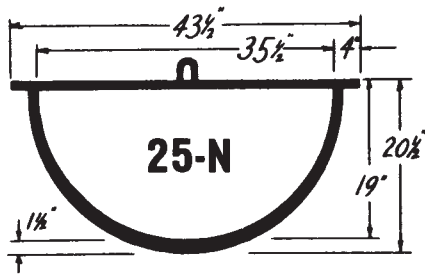

13,167 CUBIC INCHES CAPACITY — BRIMFULL
 APPROXIMATE WEIGHT OF KETTLE 1016 LBS.

CAPACITY	ALUMINUM	1267 LBS.
	DIE CAST	3160 LBS.
	ZINC	3326 LBS.
	LEAD	5406 LBS.

SETTING RING — 39 1/2" I.D., 49 1/2" O.D., 7/8" THICK

FURNISHED WITH SETTING HOOKS

Melting Kettles

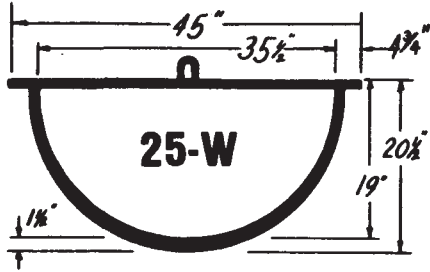

APPROXIMATE WEIGHT OF KETTLE 1160 LBS.

FURNISHED WITH SETTING HOOKS

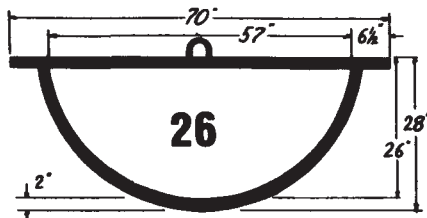

39,732 CUBIC INCHES CAPACITY — BRIMFULL
APPROXIMATE WEIGHT OF KETTLE 2550 LBS.

CAPACITY	ALUMINUM	3826 LBS.
	DIE CAST	9535 LBS.
	ZINC	10,036 LBS.
	LEAD	16,313 LBS.

SETTING RING — 61" I.D., 74" O.D., 1 1/4" THICK

FURNISHED WITH SETTING HOOKS

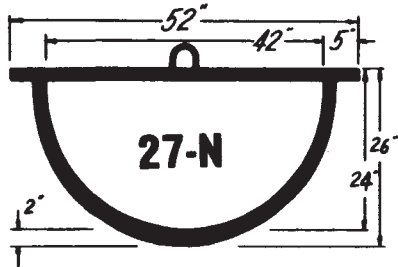

21,945 CUBIC INCHES CAPACITY — BRIMFULL
APPROXIMATE WEIGHT OF KETTLE 1880 LBS.

CAPACITY	ALUMINUM	2113 LBS.
	DIE CAST	5266 LBS.
	ZINC	5543 LBS.
	LEAD	9010 LBS.

SETTING RING — 46" I.D., 59" O.D., 1 1/4" THICK

FURNISHED WITH SETTING HOOKS

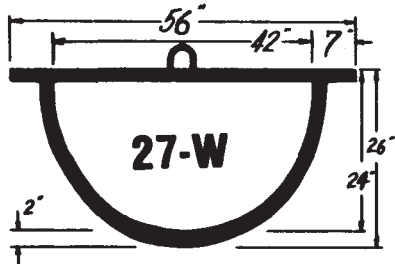

APPROXIMATE WEIGHT OF KETTLE 2045 LBS.

FURNISHED WITH SETTING HOOKS

Melting Kettles

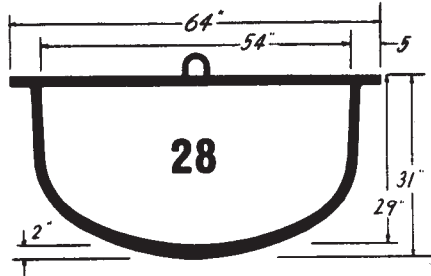

FURNISHED WITH SETTING HOOKS

47,817 CUBIC INCHES CAPACITY — BRIMFULL
 APPROXIMATE WEIGHT OF KETTLE 3150 LBS.

CAPACITY	ALUMINUM	4604 LBS.
	DIE CAST	11,476 LBS.
	ZINC	12,078 LBS.
	LEAD	19,633 LBS.

SETTING RING — 58" I.D., 74" O.D., 1¼" THICK
 SETTING RING — 58" I.D., 69" O.D., 1¼" THICK
 ALSO MADE WITH REINFORCING RIBS.
 ON LOWER HALF AND BOTTOM.

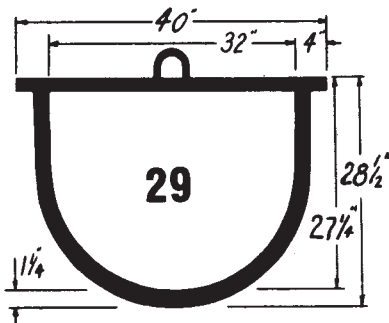

FURNISHED WITH SETTING HOOKS

15,708 CUBIC INCHES CAPACITY — BRIMFULL
 APPROXIMATE WEIGHT OF KETTLE 1120 LBS.
 WITH SPOUT 1160 LBS.

CAPACITY	ALUMINUM	1512 LBS.
	DIE CAST	4158 LBS.
	ZINC	4376 LBS.
	LEAD	6449 LBS.

SETTING RING — 36" I.D., 52" O.D., 1" THICK

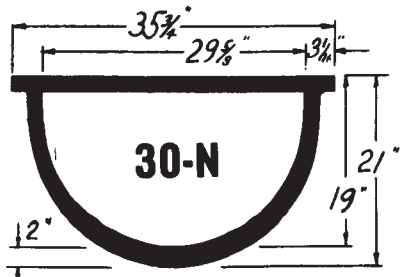

FURNISHED WITH OR WITHOUT
 SETTING HOOKS

8,316 CUBIC INCHES CAPACITY — BRIMFULL
 APPROXIMATE WEIGHT OF KETTLE 798 LBS.
 WITH XXX HEAVY WALLS 902 LBS.

CAPACITY	ALUMINUM	800 LBS.
	DIE CAST	1995 LBS.
	ZINC	2100 LBS.
	LEAD	3414 LBS.

SETTING RING — 33½" I.D., 54" O.D., 1" THICK

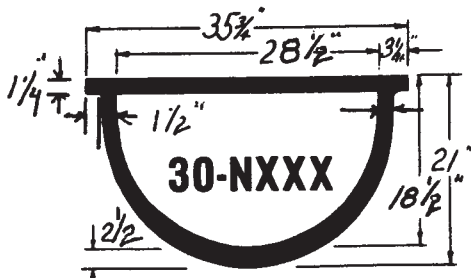

7,401 CUBIC INCHES CAPACITY — BRIMFULL
 APPROXIMATE WEIGHT OF KETTLE 902 LBS.

CAPACITY	ALUMINUM	902 LBS.
	DIE CAST	1,776 LBS.
	ZINC	1,869 LBS.
	LEAD	3,038 LBS.

SETTING RING — 33½" I.D., 54" O.D., 1" THICK

Melting Kettles

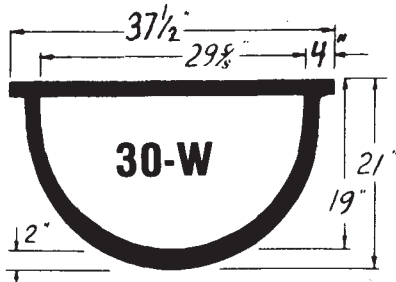

APPROXIMATE WEIGHT OF KETTLE 810 LBS.
 WITH XXX HEAVY WALLS 920 LBS.

FURNISHED WITH OR WITHOUT SETTING HOOKS

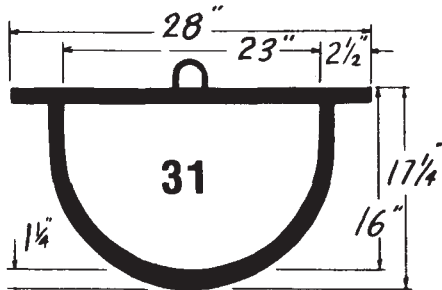

3696 CUBIC INCHES CAPACITY — BRIMFULL
 APPROXIMATE WEIGHT OF KETTLE 650 LBS.

CAPACITY ALUMINUM 355 LBS.
 DIE CAST 887 LBS.
 ZINC 933 LBS.
 • LEAD 1517 LBS.

SETTING RING — 27" I.D., 37" O.D., 1" THICK

FURNISHED WITH OR WITHOUT SETTING HOOKS

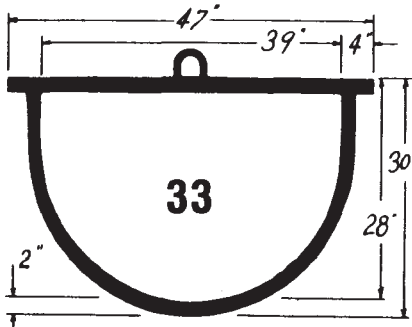

23,331 CUBIC INCHES CAPACITY — BRIMFULL
 APPROXIMATE WEIGHT OF KETTLE 1950 LBS.

CAPACITY ALUMINUM 2246 LBS.
 DIE CAST 5599 LBS.
 ZINC 5893 LBS.
 LEAD 9579 LBS.

SETTING RING — 43" I.D., 63" O.D., 1 1/4" THICK
 SETTING RING — 43" I.D., 55" O.D., 1 1/4" THICK

FURNISHED WITH SETTING HOOKS

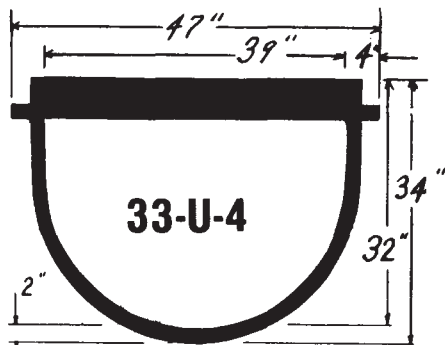

28,107 CUBIC INCHES CAPACITY — BRIMFULL
 APPROX. WEIGHT OF KETTLE W/4" UPSET... 2100 LBS.

CAPACITY ALUMINUM 2706 LBS.
 DIE CAST 6745 LBS.
 ZINC 7098 LBS.
 LEAD 11,537 LBS.

SETTING RING — 43" I.D., 63" O.D., 1 1/4" THICK
 SETTING RING — 43" I.D., 55" O.D., 1 1/4" THICK

FURNISHED WITH SETTING HOOKS

Melting Kettles

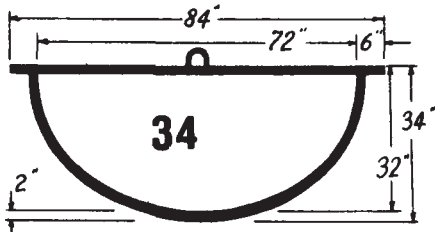

FURNISHED WITH SETTING HOOKS

77,616 CUBIC INCHES CAPACITY — BRIMFULL
APPROXIMATE WEIGHT OF KETTLE 4,950 LBS.

CAPACITY	ALUMINUM	7,474 LBS.
	DIE CAST	18,627 LBS.
	ZINC	19,605 LBS.
	LEAD	31,869 LBS.

SETTING RING — 79" I.D., 96" O.D., 1 1/4" THICK

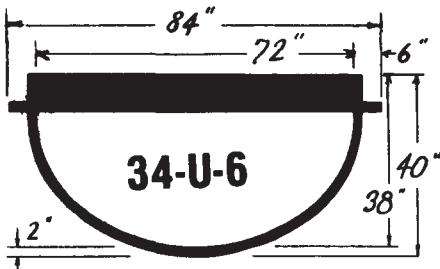

FURNISHED WITH SETTING HOOKS

107,415 CUBIC INCHES CAPACITY — BRIMFULL
APPROX. WEIGHT OF KETTLE W/6" UPSET ... 5,500 LBS.

CAPACITY	ALUMINUM	10,344 LBS.
	DIE CAST	25,779 LBS.
	ZINC	27,133 LBS.
	LEAD	44,104 LBS.

SETTING RING — 79" I.D., 96" O.D., 1 1/4" THICK

ALSO MADE WITH 9" UPSET 5,800 LBS.

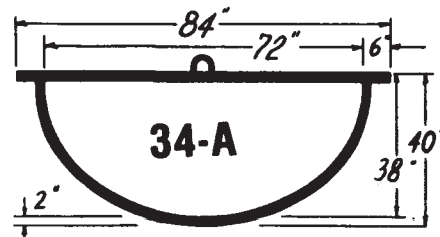

FURNISHED WITH SETTING HOOKS

107,415 CUBIC INCHES CAPACITY — BRIMFULL
APPROXIMATE WEIGHT OF KETTLE 5,400 LBS.

CAPACITY	ALUMINUM	10,344 LBS.
	DIE CAST	25,779 LBS.
	ZINC	27,133 LBS.
	LEAD	44,104 LBS.

SETTING RING — 79" I.D., 96" O.D., 1 1/4" THICK

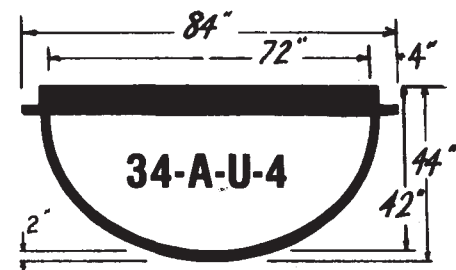

FURNISHED WITH SETTING HOOKS

123,701 CUBIC INCHES CAPACITY — BRIMFULL
APPROX. WEIGHT OF KETTLE W/4" UPSET 5,900 LBS.

CAPACITY	ALUMINUM	11,944 LBS.
	DIE CAST	29,687 LBS.
	ZINC	31,244 LBS.
	LEAD	50,780 LBS.

SETTING RING — 79" I.D., 96" O.D., 1 1/4" THICK

Melting Kettles

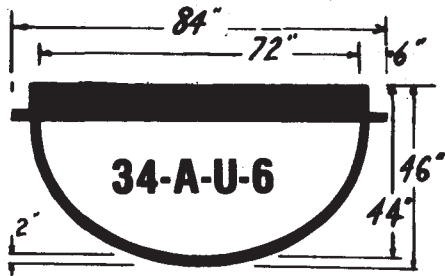

APPROX. WEIGHT OF KETTLE W/6" UPSET 6,100 LBS.

CAPACITY	ALUMINUM	12,700 LBS.
	DIE CAST	31,600 LBS.
	ZINC	33,200 LBS.
	LEAD	54,100 LBS.

SETTING RING — 79" I.D., 96" O.D., 1¼" THICK

FURNISHED WITH SETTING HOOKS

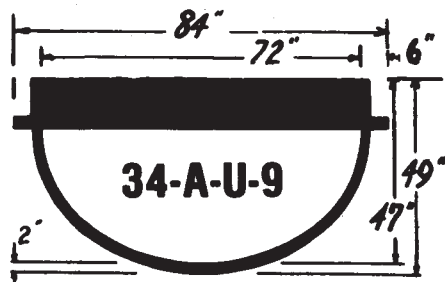

APPROX. WEIGHT OF KETTLE W/9" UPSET 6,300 LBS.

CAPACITY	ALUMINUM	13,900 LBS.
	DIE CAST	34,500 LBS.
	ZINC	36,000 LBS.
	LEAD	59,000 LBS.

SETTING RING — 79" I.D., 96" O.D., 1¼" THICK

FURNISHED WITH SETTING HOOKS

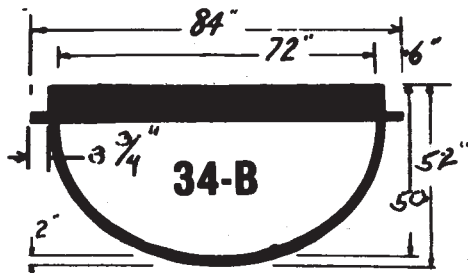

APPROX. WEIGHT OF KETTLE W/9" UPSET 6650 LBS.

CAPACITY	ALUMINUM	15116 LBS.
	DIE CAST	37496 LBS.
	ZINC	39524 LBS.
	LEAD	64137 LBS.

SETTING RING — 79" I.D., 96" O.D., 1¼" THICK

FURNISHED WITH SETTING HOOKS

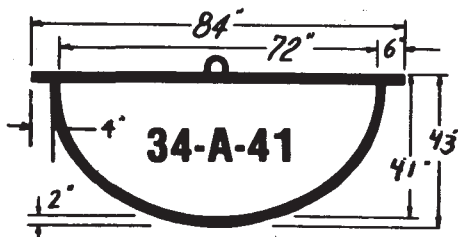

119622 CUBIC INCHES CAPACITY — BRIMFULL
APPROXIMATE WEIGHT OF KETTLE 5750 LBS.

CAPACITY	ALUMINUM	10,344 LBS.
	DIE CAST	25,779 LBS.
	ZINC	27,133 LBS.
	LEAD	44,104 LBS.

SETTING RING — 79" I.D., 96" O.D., 1¼" THICK

FURNISHED WITH SETTING HOOKS

Melting Kettles

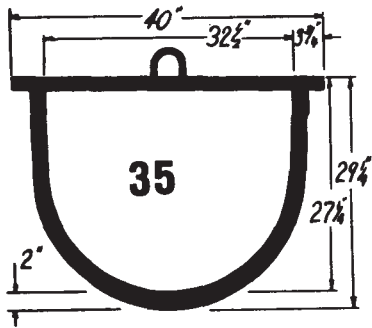

FURNISHED WITH SETTING HOOKS

17,556 CUBIC INCHES CAPACITY — BRIMFULL
 APPROXIMATE WEIGHT OF KETTLE 1465 LBS.

CAPACITY	ALUMINUM	1646 LBS.
	DIE CAST	4213 LBS.
	ZINC	4434 LBS.
	LEAD	7018 LBS.

SETTING RING — 36" I.D., 52" O.D., 1" THICK

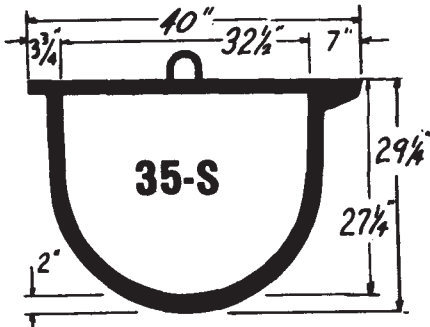

FURNISHED WITH SETTING HOOKS

APPRØX. WEIGHT OF KETTLE W/SPT. 1485 LBS.

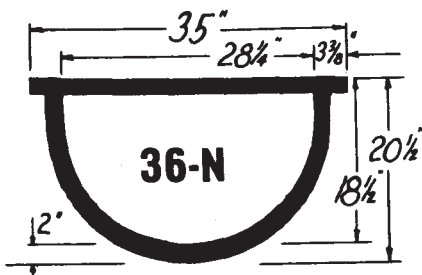

FURNISHED WITH OR WITHOUT SETTING HOOKS

WITH SPOUT 8 10 LBS.
 EXTRA HEAVY 8 40 LBS.

7,623 CUBIC INCHES CAPACITY — BRIMFULL
 APPROXIMATE WEIGHT OF KETTLE 642 LBS.

CAPACITY	ALUMINUM	734 LBS.
	DIE CAST	1829 LBS.
	ZINC	1925 LBS.
	LEAD	3130 LBS.

SETTING RING — 30 3/4" I.D., 42 3/4" O.D., 1" THICK

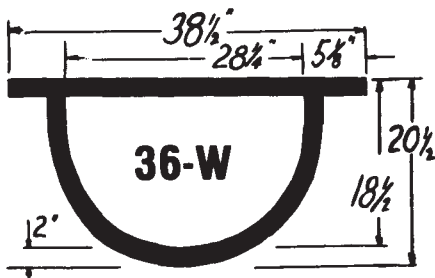

FURNISHED WITH OR WITHOUT SETTING HOOKS

APPROXIMATE WEIGHT OF KETTLE 756 LBS.

Melting Kettles

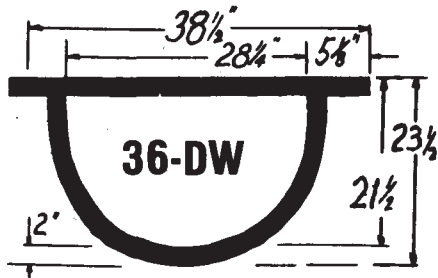

CUBIC INCHES CAPACITY — BRIMFULL
 APPROXIMATE WEIGHT OF KETTLE 835 LBS.

CAPACITY	ALUMINUM	956 LBS.
	DIE CAST	2383 LBS.
	ZINC	2509 LBS.
	LEAD	4078 LBS.

SETTING RING — 35 1/4" I.D., 62" O.D., 1 1/4" THICK
 SETTING RING — 35 1/4" I.D., 56" O.D., 1 1/4" THICK

FURNISHED WITH OR WITHOUT SETTING HOOKS

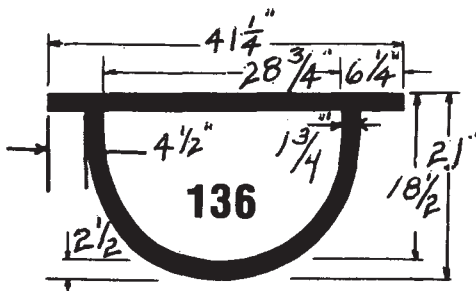

7,623 CUBIC INCHES CAPACITY — BRIMFULL
 APPROXIMATE WEIGHT OF KETTLE 1,160 LBS.

CAPACITY	ALUMINUM	765 LBS.
	DIE CAST	1,907 LBS.
	ZINC	2,005 LBS.
	LEAD	3,263 LBS.

SETTING RING — I.D., O.D., 1" THICK

FURNISHED WITH OR WITHOUT SETTING HOOKS

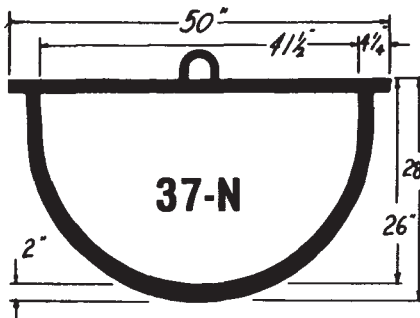

26,565 CUBIC INCHES CAPACITY — BRIMFULL
 APPROXIMATE WEIGHT OF KETTLE 2100 LBS.

CAPACITY	ALUMINUM	2558 LBS.
	DIE CAST	6375 LBS.
	ZINC	6710 LBS.
	LEAD	10,907 LBS.

SETTING RING — 45 1/2" I.D., 66 1/2" O.D., 1 1/8" THICK
 SETTING RING — 45 1/2" I.D., 57 1/2" O.D., 1 1/4" THICK

FURNISHED WITH SETTING HOOKS

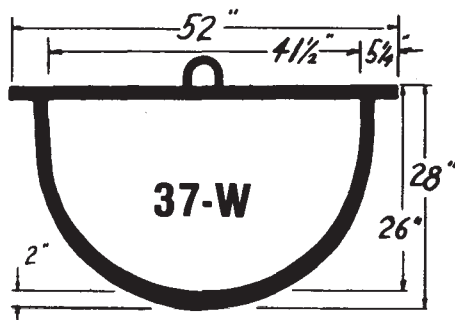

APPROXIMATE WEIGHT OF KETTLE 2150 LBS.

FURNISHED WITH SETTING HOOKS

Melting Kettles

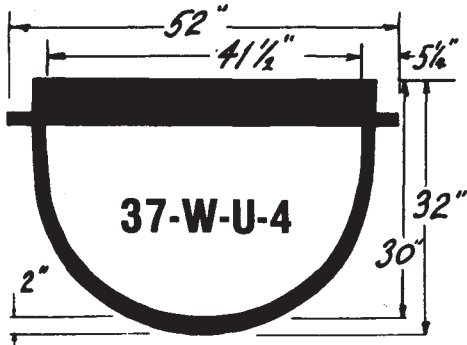

FURNISHED WITH SETTING HOOKS

32,025 CUBIC INCHES CAPACITY — BRIMFULL
APPROX. WEIGHT OF KETTLE W/4" UPSET ... 2390 LBS.

CAPACITY	ALUMINUM	3058 LBS.
	DIE CAST	7672 LBS.
	ZINC	8075 LBS.
	LEAD	13,124 LBS.

SETTING RING — 45 1/2" I.D., 66 1/2" O.D., 1 1/8" THICK
SETTING RING — 45 1/2" I.D., 57 1/2" O.D., 1 1/4" THICK

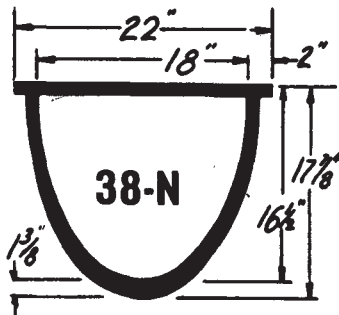

FURNISHED WITH OR WITHOUT SETTING HOOKS

2,772 CUBIC INCHES CAPACITY — BRIMFULL
APPROXIMATE WEIGHT OF KETTLE 265 LBS.

CAPACITY	ALUMINUM	266 LBS.
	DIE CAST	665 LBS.
	ZINC	700 LBS.
	LEAD	1138 LBS.

SETTING RING — 20" I.D., 32" O.D., 3/4" THICK

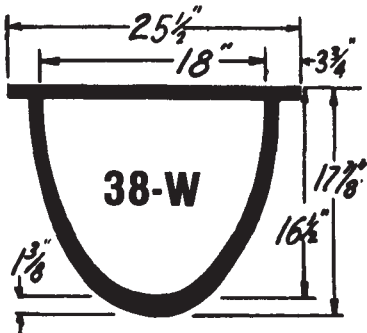

FURNISHED WITH OR WITHOUT SETTING HOOKS

APPROXIMATE WEIGHT OF KETTLE 275 LBS.

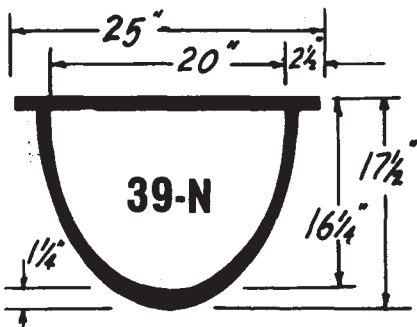

FURNISHED WITH OR WITHOUT SETTING HOOKS

3,234 CUBIC INCHES CAPACITY — BRIMFULL
APPROXIMATE WEIGHT OF KETTLE 395 LBS.

CAPACITY	ALUMINUM	311 LBS.
	DIE CAST	776 LBS.
	ZINC	816 LBS.
	LEAD	1327 LBS.

SETTING RING — 22" I.D., 41" O.D., 1 1/4" THICK

Melting Kettles

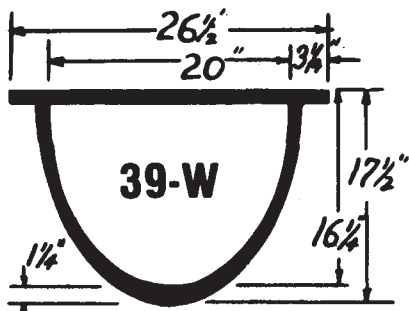

APPROXIMATE WEIGHT OF KETTLE 400 LBS.

FURNISHED WITH OR WITHOUT SETTING HOOKS

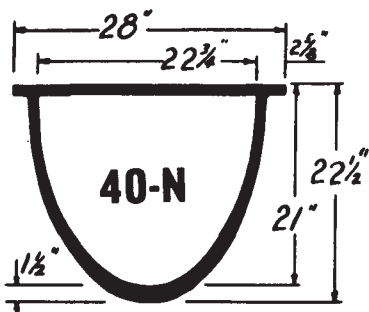

5,544 CUBIC INCHES CAPACITY — BRIMFULL
APPROXIMATE WEIGHT OF KETTLE 460 LBS.

CAPACITY	ALUMINUM	533 LBS.
	DIE CAST	1330 LBS.
	ZINC	1400 LBS.
	LEAD	2276 LBS.

FURNISHED WITH OR WITHOUT SETTING HOOKS

SETTING RING — 25" I.D., 43" O.D., 3/4" THICK

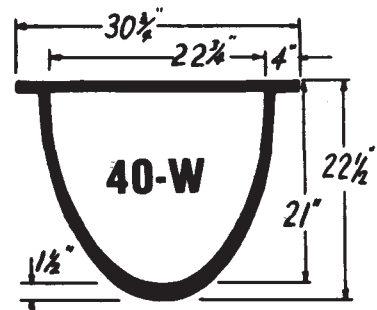

APPROXIMATE WEIGHT OF KETTLE 470 LBS.

FURNISHED WITH OR WITHOUT SETTING HOOKS

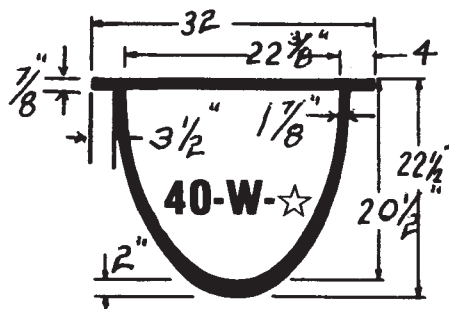

5,266 CUBIC INCHES CAPACITY — BRIMFULL
APPROXIMATE WEIGHT OF KETTLE 590 LBS.

CAPACITY	ALUMINUM	506 LBS.
	DIE CAST	1,263 LBS.
	ZINC	1,330 LBS.
	LEAD	2,162 LBS.

SETTING RING — 25" I.D., 43" O.D., 3/4" THICK

FURNISHED WITH OR WITHOUT SETTING HOOKS

NO. 40W WITH STAR 590 LBS.
REDUCED I.D.

Melting Kettles

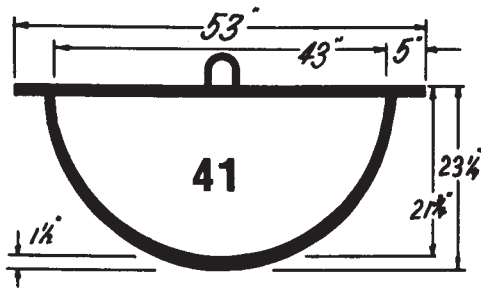

FURNISHED WITH SETTING HOOKS

19,866 CUBIC INCHES CAPACITY — BRIMFULL
 APPROXIMATE WEIGHT OF KETTLE 1612 LBS.

CAPACITY	ALUMINUM	1913 LBS.
	DIE CAST	4767 LBS.
	ZINC	5018 LBS.
	LEAD	8156 LBS.

SETTING RING — 46 1/2" I.D., 58 1/2" O.D., 1 1/4" THICK
 ALSO WITH 12" FLANGE 1,950 LBS.

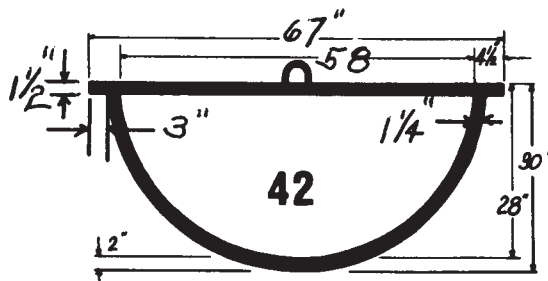

FURNISHED WITH SETTING HOOKS

46,200 CUBIC INCHES CAPACITY — BRIMFULL
 APPROXIMATE WEIGHT OF KETTLE 2530 LBS.

CAPACITY	ALUMINUM	4449 LBS.
	DIE CAST	11,088 LBS.
	ZINC	11,670 LBS.
	LEAD	18,969 LBS.

SETTING RING — 61" I.D., 74" O.D., 1 1/4" THICK

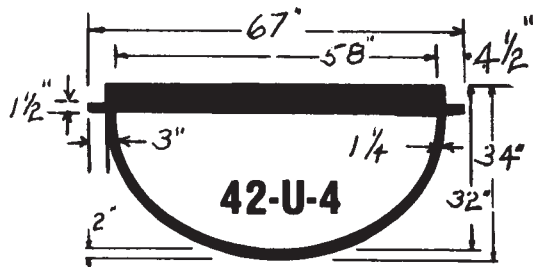

FURNISHED WITH SETTING HOOKS

CUBIC INCHES CAPACITY — BRIMFULL
 APPROXIMATE WEIGHT OF KETTLE 2930 LBS.

CAPACITY	ALUMINUM	5400 LBS.
	DIE CAST	13,000 LBS.
	ZINC	14,200 LBS.
	LEAD	23,000 LBS.

SETTING RING — 61" I.D., 74" O.D., 1 1/4" THICK

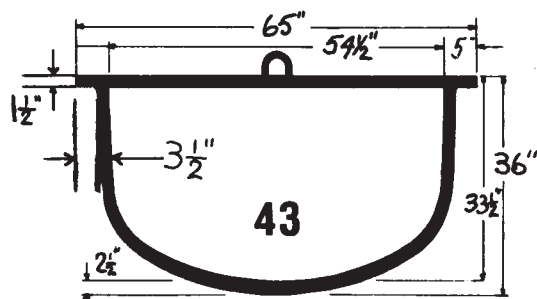

FURNISHED WITH SETTING HOOKS

57,750 CUBIC INCHES CAPACITY — BRIMFULL
 APPROXIMATE WEIGHT OF KETTLE 3500 LBS.

CAPACITY	ALUMINUM	5560 LBS.
	DIE CAST	13,860 LBS.
	ZINC	14,586 LBS.
	LEAD	23,712 LBS.

SETTING RING — 61 1/2" I.D., 76 1/2" O.D., 1" THICK
 ALSO WITH 7" FLANGE 3,620 LBS.
 AND RIBS ON BOTTOM.

Melting Kettles

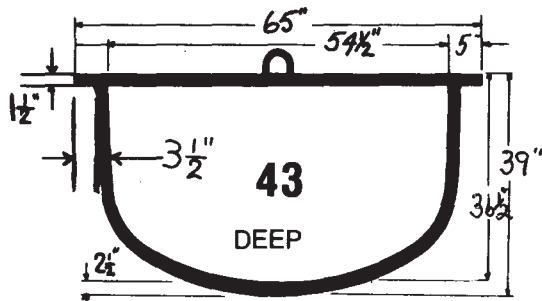

FURNISHED WITH SETTING HOOKS

57,750 CUBIC INCHES CAPACITY — BRIMFULL
APPROXIMATE WEIGHT OF KETTLE 4400 LBS.

CAPACITY ALUMINUM 6000 LBS.
DIE CAST 15,000 LBS.
ZINC 15,750 LBS.
LEAD 25,660 LBS.

SETTING RING — 61 1/2" I.D., 76 1/2" O.D., 1" THICK
ALSO WITH 7" FLANGE 3,620 LBS.
AND RIBS ON BOTTOM.

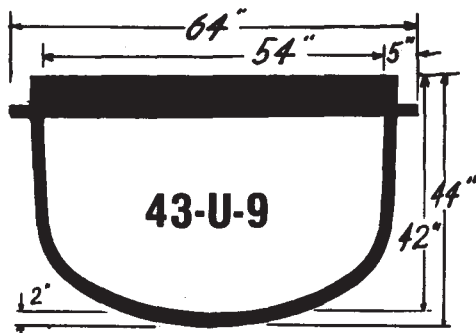

FURNISHED WITH SETTING HOOKS

78,360 CUBIC INCHES CAPACITY — BRIMFULL
APPROX. WEIGHT OF KETTLE W/9" UPSET . . . 4000 LBS.

CAPACITY ALUMINUM 7560 LBS.
DIE CAST 18,806 LBS.
ZINC 19,790 LBS.
LEAD 32,162 LBS.

SETTING RING — 61 1/2" I.D., 76 1/2" O.D., 1" THICK

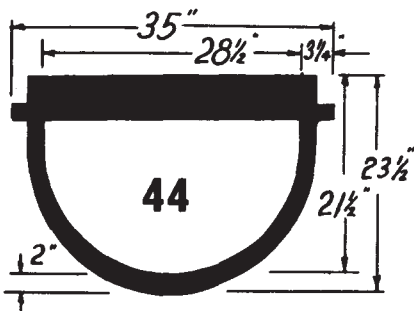

FURNISHED WITH OR WITHOUT SETTING HOOKS

9,933 CUBIC INCHES CAPACITY — BRIMFULL
APPROXIMATE WEIGHT OF KETTLE 835 LBS.

CAPACITY ALUMINUM 956 LBS.
DIE CAST 2383 LBS.
ZINC 2509 LBS.
LEAD 4078 LBS.

SETTING RING — 30 3/4" I.D., 42 3/4" O.D., 1" THICK

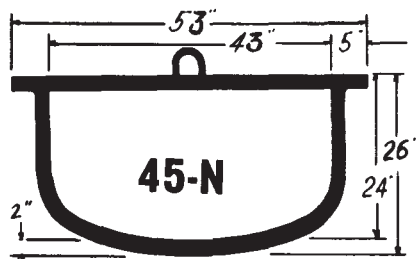

FURNISHED WITH SETTING HOOKS

25,872 CUBIC INCHES CAPACITY — BRIMFULL
APPROXIMATE WEIGHT OF KETTLE 1860 LBS.

CAPACITY ALUMINUM 2491 LBS.
DIE CAST 6209 LBS.
ZINC 6535 LBS.
LEAD 10,623 LBS.

SETTING RING — 46 1/2" I.D., 58 1/2" O.D., 1 1/4" THICK

Melting Kettles

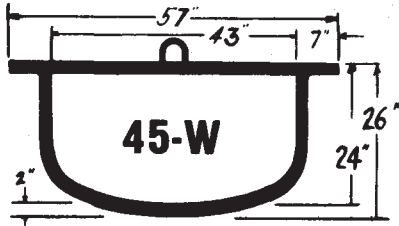

APPROXIMATE WEIGHT OF KETTLE 1920 LBS.

FURNISHED WITH SETTING HOOKS

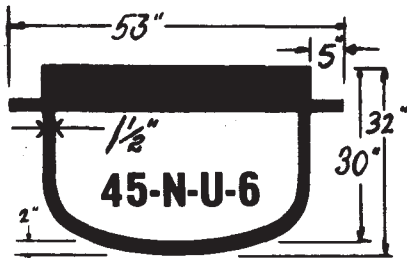

34,182 CUBIC INCHES CAPACITY — BRIMFULL
APPROX. WEIGHT OF KETTLE W/6" UPSET ... 2150 LBS.

CAPACITY	ALUMINUM	3291 LBS.
	DIE CAST	8203 LBS.
	ZINC	8545 LBS.
	LEAD	14,014 LBS.

SETTING RING — 46½" I.D., 58½" O.D., 1¼" THICK

FURNISHED WITH SETTING HOOKS

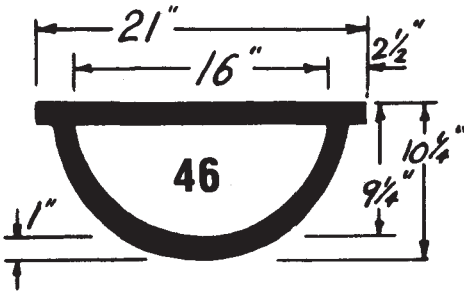

1,386 CUBIC INCHES CAPACITY — BRIMFULL
APPROXIMATE WEIGHT OF KETTLE 158 LBS.

CAPACITY	ALUMINUM	133 LBS.
	DIE CAST	332 LBS.
	ZINC	350 LBS.
	LEAD	569 LBS.

SETTING RING — 19" I.D., 28" O.D., 1" THICK

FURNISHED WITH SETTING HOOKS

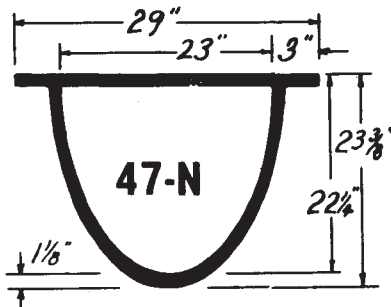

7,161 CUBIC INCHES CAPACITY — BRIMFULL
APPROXIMATE WEIGHT OF KETTLE 600 LBS.

CAPACITY	ALUMINUM	689 LBS.
	DIE CAST	1718 LBS.
	ZINC	1808 LBS.
	LEAD	2940 LBS.

SETTING RING — 25¾" I.D., 37¾" O.D., 1" THICK

FURNISHED WITH OR WITHOUT
SETTING HOOKS

Melting Kettles

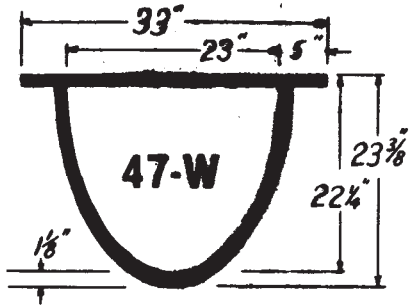

APPROXIMATE WEIGHT OF KETTLE 620 LBS.

FURNISHED WITH OR WITHOUT SETTING HOOKS

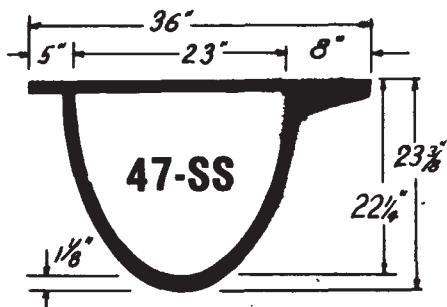

7,161 CUBIC INCHES CAPACITY — BRIMFULL
APPROXIMATE WEIGHT OF KETTLE 610 LBS.

CAPACITY	ALUMINUM	689 LBS.
	DIE CAST	1718 LBS.
	ZINC	1808 LBS.
	LEAD	2940 LBS.

SETTING RING — 45 1/2" I.D., 66 1/2" O.D., 1 1/8" THICK

FURNISHED WITH OR WITHOUT SETTING HOOKS

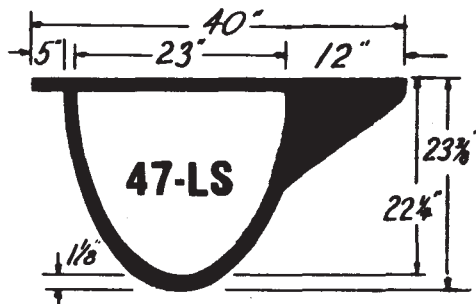

APPROXIMATE WEIGHT OF KETTLE 640 LBS.
ALSO MADE WITH 6" THICK BOTTOM 722 LBS.

FURNISHED WITH OR WITHOUT SETTING HOOKS

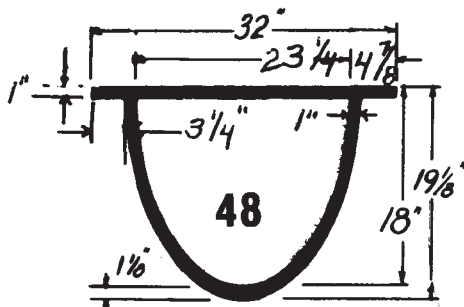

5,313 CUBIC INCHES CAPACITY — BRIMFULL
APPROXIMATE WEIGHT OF KETTLE 500 LBS.

CAPACITY	ALUMINUM	511 LBS.
	DIE CAST	1275 LBS.
	ZINC	1342 LBS.
	LEAD	2181 LBS.

SETTING RING — 27" I.D., 37" O.D., 1" THICK

FURNISHED WITH OR WITHOUT SETTING HOOKS

Melting Kettles

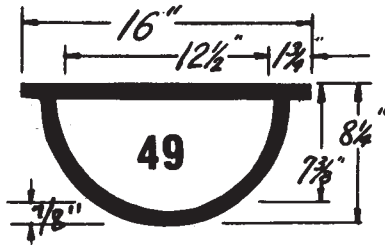

693 CUBIC INCHES CAPACITY — BRIMFULL
 APPROXIMATE WEIGHT OF KETTLE 90 LBS.

CAPACITY	ALUMINUM	66 LBS.
	DIE CAST	166 LBS.
	ZINC	175 LBS.
	LEAD	284 LBS.

FURNISHED WITHOUT SETTING HOOKS

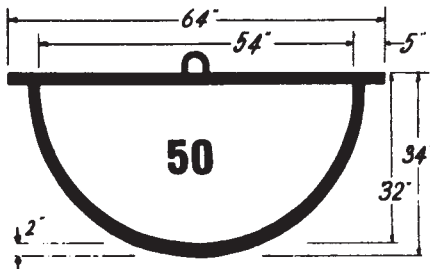

48,048 CUBIC INCHES CAPACITY — BRIMFULL
 APPROXIMATE WEIGHT OF KETTLE 3080 LBS.

CAPACITY	ALUMINUM	4627 LBS.
	DIE CAST	11,531 LBS.
	ZINC	12,136 LBS.
	LEAD	19,728 LBS.

SETTING RING — 60" I.D., 73 3/4" O.D., 1 1/2" THICK
 ALSO MADE WITH 4" UPSET 3,450 LBS.

FURNISHED WITH SETTING HOOKS

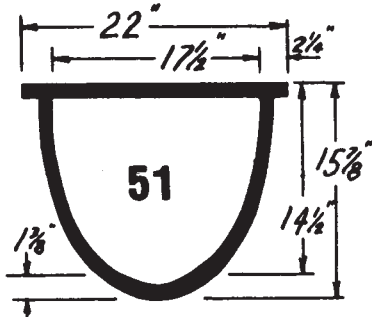

2,310 CUBIC INCHES CAPACITY — BRIMFULL
 APPROXIMATE WEIGHT OF KETTLE 240 LBS.

CAPACITY	ALUMINUM	222 LBS.
	DIE CAST	554 LBS.
	ZINC	583 LBS.
	LEAD	948 LBS.

SETTING RING — 20" I.D., 32" O.D., 3/4" THICK

FURNISHED WITH OR WITHOUT SETTING HOOKS

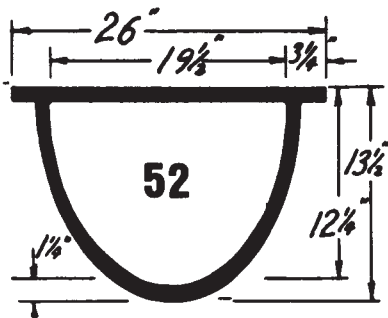

2,310 CUBIC INCHES CAPACITY — BRIMFULL
 APPROXIMATE WEIGHT OF KETTLE 350 LBS.

CAPACITY	ALUMINUM	222 LBS.
	DIE CAST	554 LBS.
	ZINC	583 LBS.
	LEAD	948 LBS.

SETTING RING — 22" I.D., 41" O.D., 1 1/4" THICK

FURNISHED WITH OR WITHOUT SETTING HOOKS

Melting Kettles

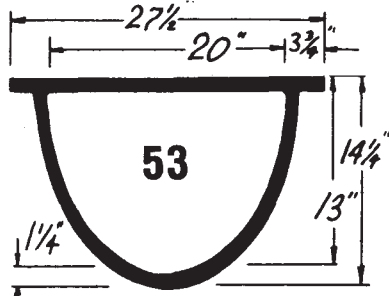

3,234 CUBIC INCHES CAPACITY — BRIMFULL
 APPROXIMATE WEIGHT OF KETTLE 280 LBS.

CAPACITY	ALUMINUM	311 LBS.
	DIE CAST	776 LBS.
	ZINC	816 LBS.
	LEAD	1327 LBS.

SETTING RING — 22" I.D., 41" O.D., 1 1/4" THICK

FURNISHED WITH OR WITHOUT SETTING HOOKS

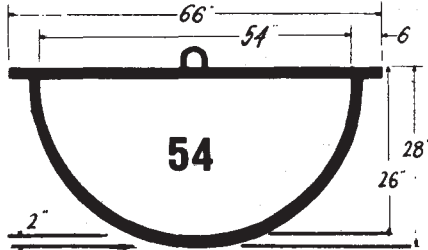

38,115 CUBIC INCHES CAPACITY — BRIMFULL
 APPROXIMATE WEIGHT OF KETTLE 2540 LBS.

CAPACITY	ALUMINUM	3670 LBS.
	DIE CAST	9147 LBS.
	ZINC	9627 LBS.
	LEAD	15,650 LBS.

SETTING RING — 58" I.D., 74" O.D., 1 1/4" THICK
 SETTING RING — 58" I.D., 69" O.D., 1 1/4" THICK

FURNISHED WITH SETTING HOOKS

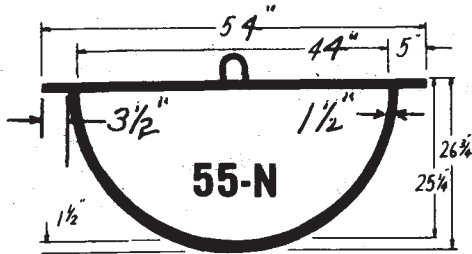

24,486 CUBIC INCHES CAPACITY — BRIMFULL
 APPROXIMATE WEIGHT OF KETTLE 1770 LBS.

CAPACITY	ALUMINUM	2358 LBS.
	DIE CAST	5876 LBS.
	ZINC	6185 LBS.
	LEAD	10,053 LBS.

SETTING RING — 48 1/2" I.D., 61" O.D., 1 1/4" THICK

FURNISHED WITH SETTING HOOKS

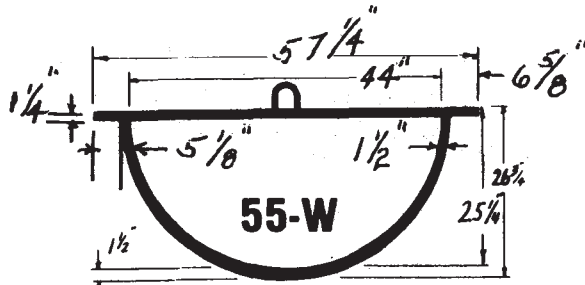

APPROXIMATE WEIGHT OF KETTLE 1790 LBS.

FURNISHED WITH SETTING HOOKS

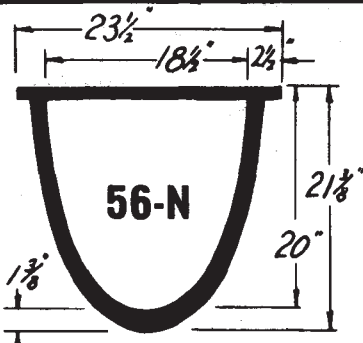

3,696 CUBIC INCHES CAPACITY — BRIMFULL
 APPROXIMATE WEIGHT OF KETTLE 320 LBS.

CAPACITY	ALUMINUM	355 LBS.
	DIE CAST	887 LBS.
	ZINC	933 LBS.
	LEAD	1517 LBS.

SETTING RING — 20" I.D., 32" O.D., 3/4" THICK

FURNISHED WITH OR WITHOUT SETTING HOOKS

Melting Kettles

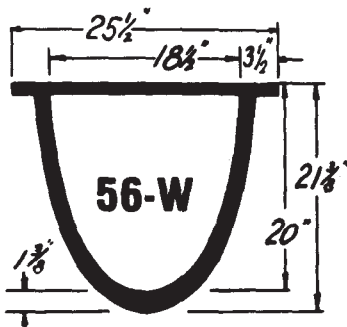

APPROXIMATE WEIGHT OF KETTLE 330 LBS.

FURNISHED WITH OR WITHOUT SETTING HOOKS

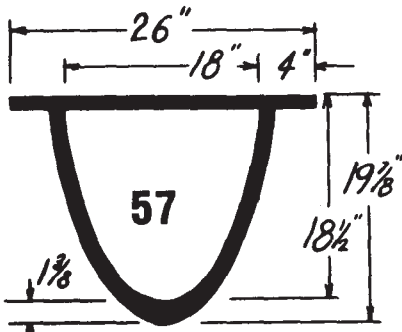

3,234 CUBIC INCHES CAPACITY — BRIMFULL
APPROXIMATE WEIGHT OF KETTLE 320 LBS.

CAPACITY	ALUMINUM	311 LBS.
	DIE CAST	776 LBS.
	ZINC	816 LBS.
	LEAD	1327 LBS.

SETTING RING — 21" I.D., 45" O.D., 1" THICK

FURNISHED WITH OR WITHOUT SETTING HOOKS

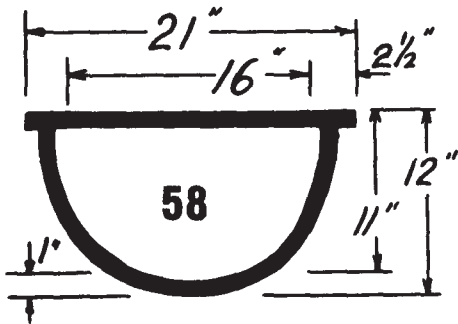

1,848 CUBIC INCHES CAPACITY — BRIMFULL
APPROXIMATE WEIGHT OF KETTLE 175 LBS.

CAPACITY	ALUMINUM	177 LBS.
	DIE CAST	443 LBS.
	ZINC	467 LBS.
	LEAD	759 LBS.

SETTING RING — 19" I.D., 28" O.D., 1" THICK

FURNISHED WITH OR WITHOUT SETTING HOOKS

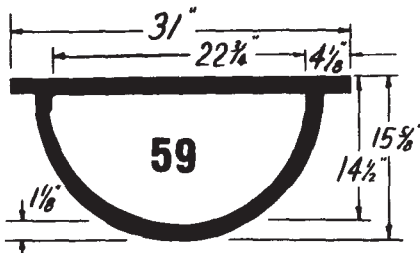

4,158 CUBIC INCHES CAPACITY — BRIMFULL
APPROXIMATE WEIGHT OF KETTLE 360 LBS.

CAPACITY	ALUMINUM	400 LBS.
	DIE CAST	997 LBS.
	ZINC	1050 LBS.
	LEAD	1707 LBS.

SETTING RING — 27" I.D., 37" O.D., 1" THICK

FURNISHED WITH OR WITHOUT SETTING HOOKS

Melting Kettles

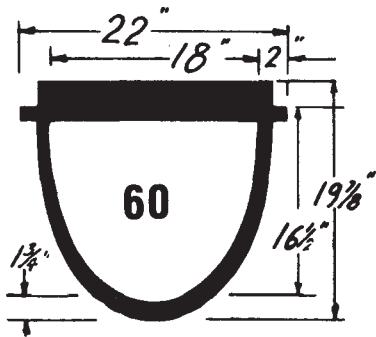

2,772 CUBIC INCHES CAPACITY — BRIMFULL
 APPROXIMATE WEIGHT OF KETTLE 280 LBS.

CAPACITY	ALUMINUM	266 LBS.
	DIE CAST	665 LBS.
	ZINC	700 LBS.
	LEAD	1138 LBS.

SETTING RING — 20" I.D., 32" O.D., 3/4" THICK

FURNISHED WITH OR WITHOUT SETTING HOOKS

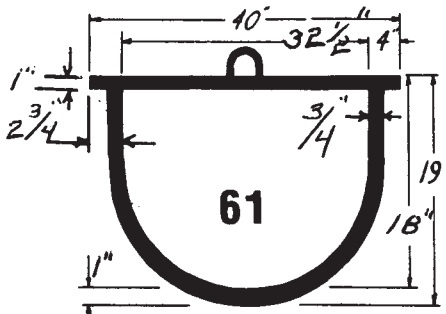

9,500 CUBIC INCHES CAPACITY — BRIMFULL
 APPROXIMATE WEIGHT OF KETTLE 640 LBS.

CAPACITY	ALUMINUM	912 LBS.
	DIE CAST	2273 LBS.
	ZINC	2392 LBS.
	LEAD	3888 LBS.

SETTING RING — 36" I.D., 52" O.D., 1" THICK

REGULAR WITH SPOUT 670 LBS.
 HEAVY WITH SPOUT 750 LBS.

FURNISHED WITH SETTING HOOKS

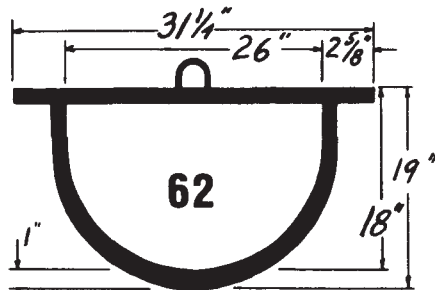

6699 CUBIC INCHES CAPACITY — BRIMFULL
 APPROXIMATE WEIGHT OF KETTLE 575 LBS.

CAPACITY	ALUMINUM	645 LBS.
	DIE CAST	1607 LBS.
	ZINC	1692 LBS.
	LEAD	2750 LBS.

SETTING RING — 28" I.D., 36" O.D., 1" THICK

FURNISHED WITH SETTING HOOKS

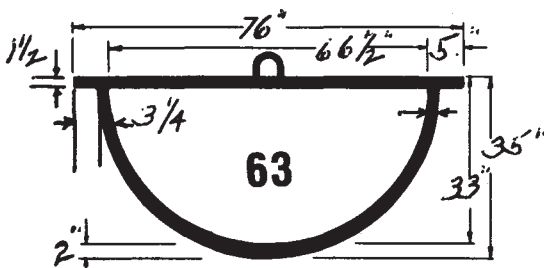

75,078 CUBIC INCHES CAPACITY — BRIMFULL
 APPROXIMATE WEIGHT OF KETTLE 4,280 LBS.

CAPACITY	ALUMINUM	7,207 LBS.
	DIE CAST	18,094 LBS.
	ZINC	18,619 LBS.
	LEAD	30,857 LBS.

SETTING RING — 61" I.D., 74" O.D., 1 1/4" THICK

FURNISHED WITH SETTING HOOKS

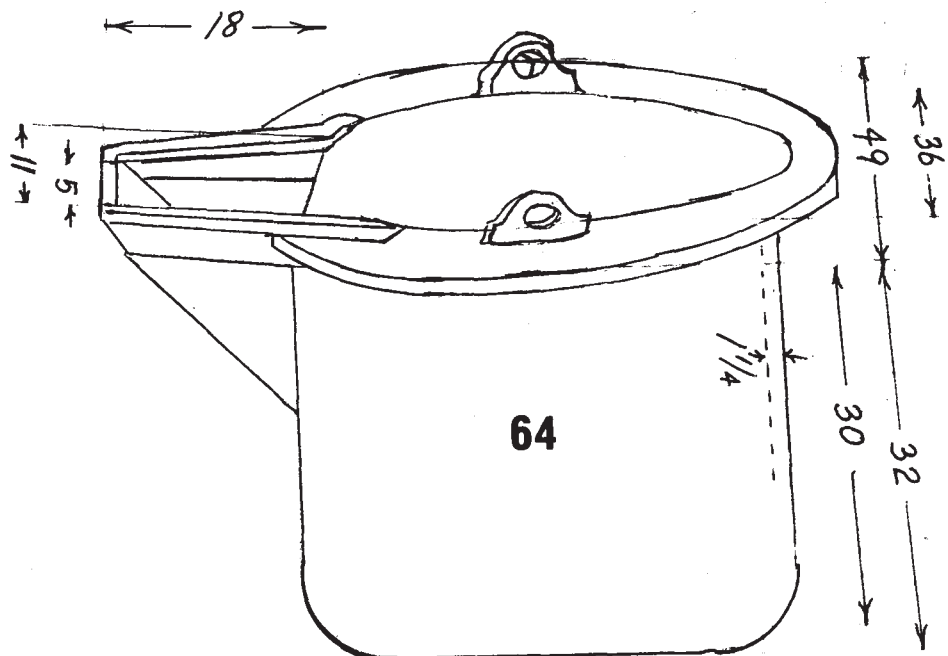

NO. 64

**FOR USE IN A
TILTING FURNACE**
APPROXIMATE WEIGHT 2150 LBS.

APPROXIMATE WEIGHT 2370 LBS.
ZINC CAPACITY 5500 LBS.

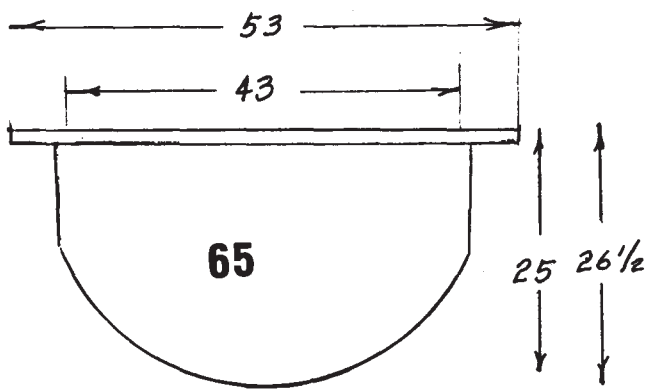

48" Kirksite Melting Kettle for tilting furnace

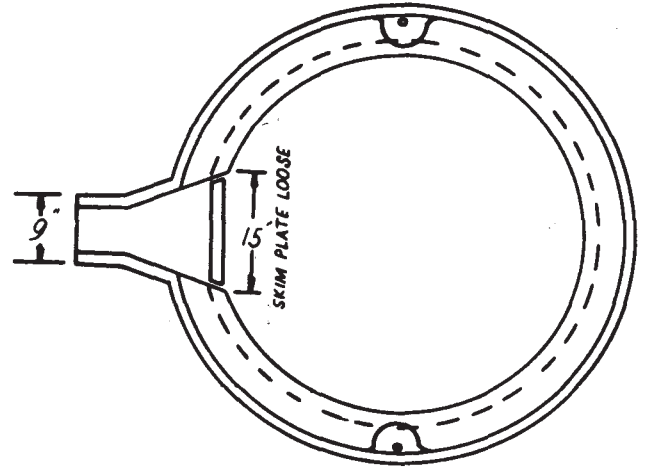
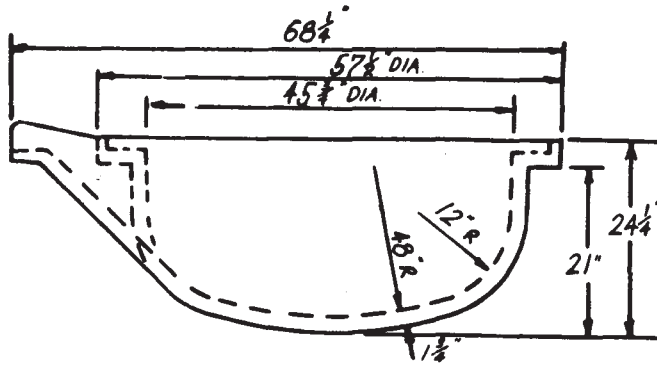

APPROXIMATE WEIGHT OF KETTLE 2500 LBS.
 APPROXIMATE CAPACITY 5000 LBS.

54" Kirksite Melting Kettle for tilting furnace

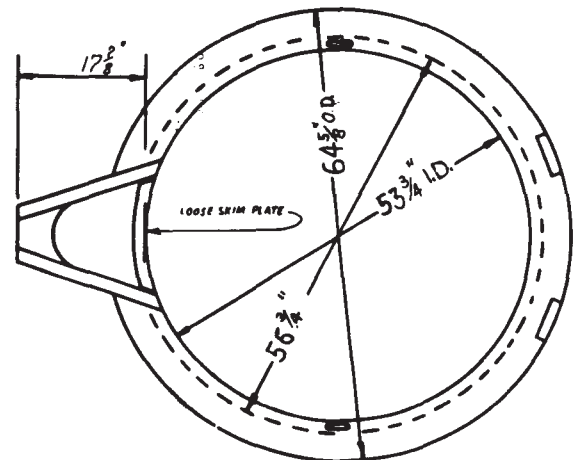
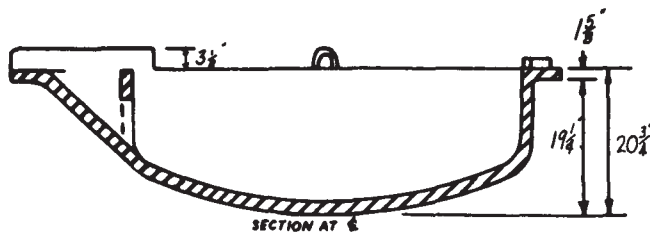

APPROXIMATE WEIGHT OF KETTLE 2564 LBS.
 APPROXIMATE CAPACITY 8500 LBS.

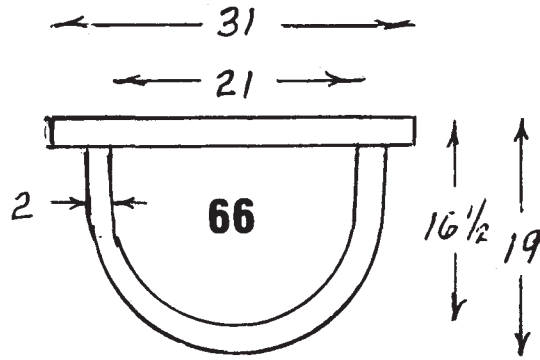

**APPROXIMATE WEIGHT OF
METAL PER CUBIC FOOT**

**APPROXIMATE WEIGHT OF LIQUID
METAL PER CUBIC INCH**

Aluminum Cast	160 #	.08
Brass (Rolled)	524	.28
Brass (Swarf)	157	
Babbitt	454	.26
Bronze	534	.28
Cast Iron	450	.26
Copper Cast	548	.30
Copper Slag	150	
Gold (Cast Pure)	1200	.42
Gold 22 Carat	1090	.42
Lead	710	.39
Silver (Cast Pure)	656	.38
Steel (Mean)	490	.26
Tin (Pure)	453	.26
Zinc (Rolled)	428	.25
Zinc (Rolled)	448	.25

Correct Kettle Setting

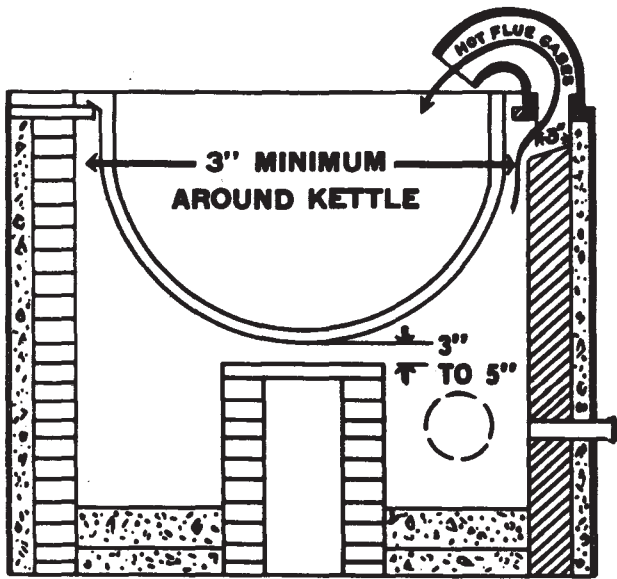

Illustration no. 1

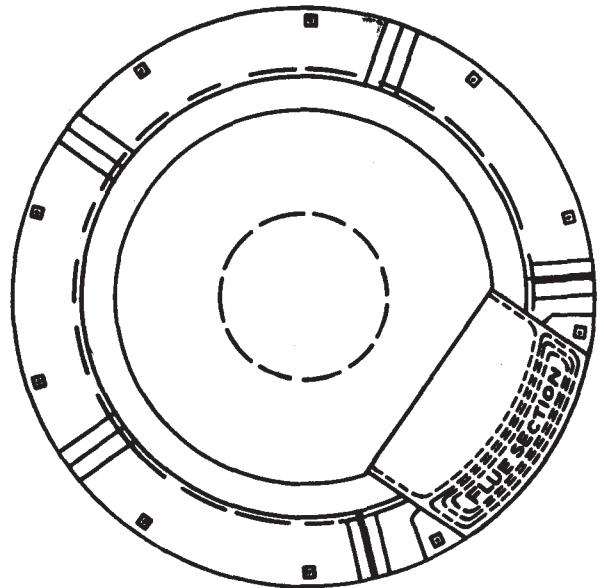

Illustration no. 1

FLUE SECTION TO BE APPROX. 1 SQ. IN. FOR EACH 20,000 BTU'S PER HR. INPUT

FAULTY KETTLE SETTING

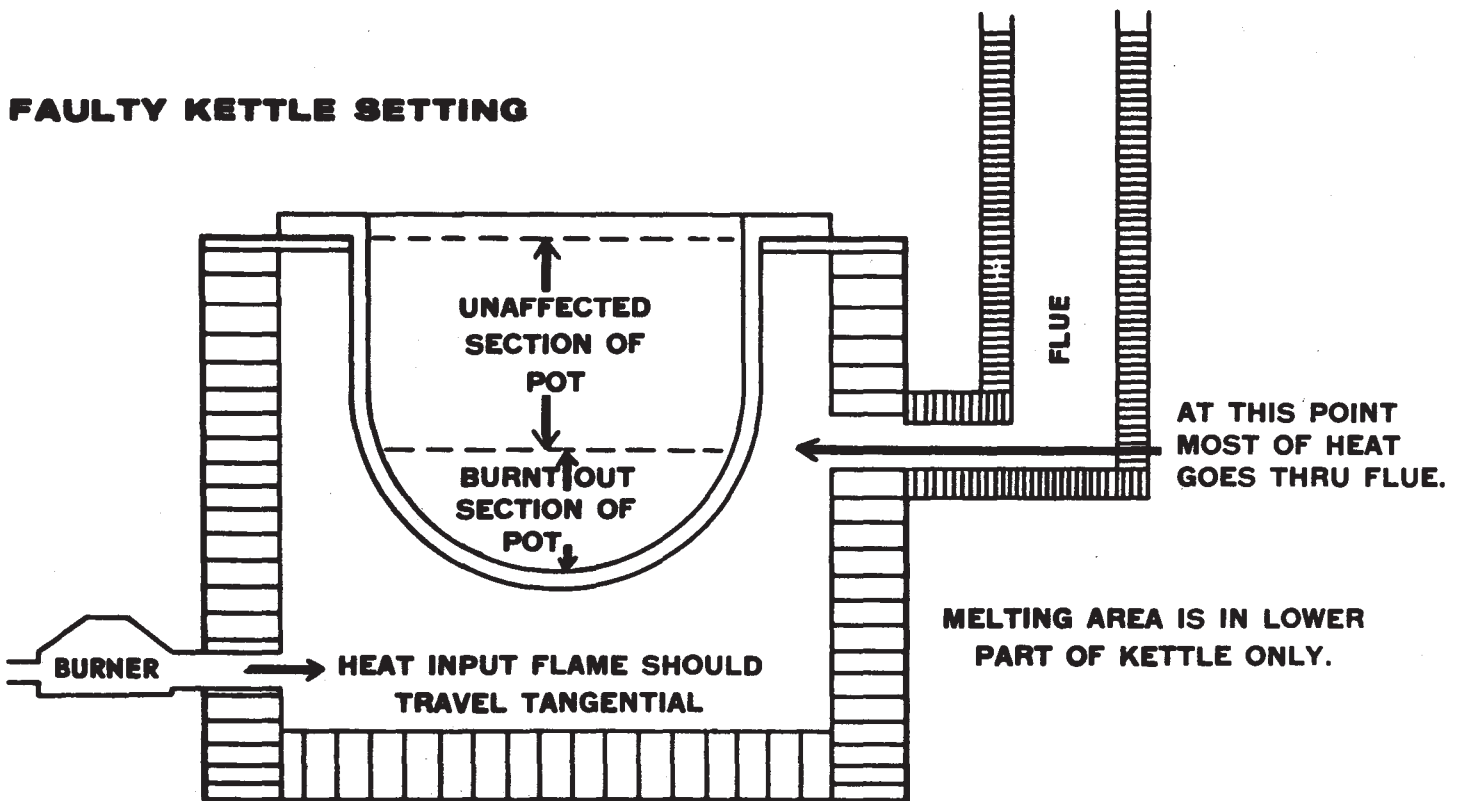

Illustration no. 2

factors affecting cast iron kettle life

kettle setting

The furnace should be built so as to allow a three inch minimum clearance between the outside of the kettle and inside of brickwork at top of kettle setting. Less than 3" will pinch off flow of heat. The furnace should be constructed with a castable insulation material between the steel shell and the brick. This will eliminate heat loss. Any heat that is lost through the wall of the furnace is taken away from the melting area. This usually results in the operator raising the burners to a point that overheats the kettle. A circle of brick should be built from the floor of the furnace to within three inches of the bottom of the kettle. This casts a shadow on the bottom of the pot and eliminates hot spots. (See illustration No. 1.)

flue

Improper flue sizes and wrong locations of flues are some of the most common causes for short pot life. The correct flue size for iron furnaces is one square inch for each 20,000 BTU's of heat per hour used under the kettle. This flue size should produce a back pressure in the furnace of .04 inch water column. If the furnace pressure is above or below this value the flue size should be increased or decreased, accordingly. The water column may be determined by the purchase of an inexpensive "Drafrite Draft Gauge."

In most cases the flues are closed off by dirt and broken bricks; this causes an excessive back pressure and the result is a pounding of flame on the kettle. In many cases the flue is located on a line with the center of the height of the kettle. The flame traveling in a tangential course reaches the flue opening and most of the heat is dissipated through the flue without reaching the top of the kettle. This heat loss forces the operator to increase the heat input and the result is a burnt lower half of the kettle and an unused top half. (Illustration No. 2.) When a kettle is being replaced the operator should take note of whether the kettle has a burnt out look at the bottom and a new kettle appearance at the top. If this is the case then the flue should be closed off completely and the kettle raised approximately two inches above the setting ring in order to force the flame to travel up to and around the flange. The illustration (No. 1) shows a proven and very efficient flue installation. This installation, or the above mentioned change, increases the area of kettle wall through which heat is transferred.

burners

There is a limit to the heat that an iron pot can transfer without damage to the kettle. This seems to be in the range of 125 to 150 BTU's per pound of kettle capacity, in terms of zinc. The temperature gradient that exists in the wall of an iron kettle brought rapidly from room temperature to melting temperature causes severe strain. The outside of the kettle is very hot and expands rapidly, while the inside surface is cold and holds back. A new kettle is elastic, but an old kettle, subject to fatigue, cannot stand the strain and tears. This is the familiar crack that brings premature death to so many kettles. This strain can be reduced or eliminated by:

1. Throttling the burners at low fire during the first two hours of warm-up.
2. Running the furnace 24 hours a day, 7 days a week.
3. Covering the kettle with any kind of cover. This will reduce the gradient and will speed melting, just as a covered pan of water will come to a boil more rapidly than an uncovered one.
4. The use of a low-fire night burner approximately 20% of full capacity of day burner.

When starting a cold furnace (during the first two hours of operation) the lining of the furnace and the kettle absorb enormous quantities of heat. At this time little heat is transferred to the charge. To overcome this lag, excessive temperatures are often built up in the combustion chamber in an attempt to accelerate the melting. The strains described above are tearing at the kettle in proportion to the difference between the temperature outside of the kettle and the temperature at the inside of the kettle. All of this can be eliminated by following one of the above four suggestions.

After the brick lining of the furnace and the kettle itself are saturated with heat, the charge will melt rapidly. Probably it is a mistake to apply more heat to a kettle than the amount that will bring down a charge in four hours, starting with a kettle and lining saturated with heat. Another measure of maximum heat is in the amount of heat that will melt one-half the capacity of the kettle in one hour, starting with half a kettle of liquid metal and a lining that is thoroughly saturated with heat. On kettles over 6,000 pounds capacity fractions should be changed from one-half and one-half

to one-third and two-thirds. This difference is due to the reduction of wall area of heat transfer per ton of capacity as the capacity of the kettle increases.

Burners should be checked at least once a month, not only for correct mixture but also to see that burners have not moved out of position. A slight variation in the position of the burners may cause flame impingement. Kettles that are heated by one or two burners should be rotated once a week. This will allow them to wear more evenly.

miscellaneous

Do not allow a full kettle of metal to freeze. This causes cracking of kettles due to expansion of metal when kettle is again put into operation.

Metal should never be overheated. This overheating not only ruins the kettle but also contaminates the metal itself by an iron pick-up from the kettle. Iron pick-up is very nominal when the metal is not allowed to overheat.

Improper loading of kettles: Melting is done by the metal contacting the kettle. Hit or miss loading of ingots results in their touching the kettle only at points. We suggest that the metal be loaded by hand as much as possible, arranging the flat side of the ingots against the side of the kettle. Then the heat applied to the kettle will be transferred to the metal, and will not overheat the kettle.

Whenever possible keep a molten heel of metal in the kettle. Never take out all the metal from a kettle and then recharge with all cold ingots. This not only slows up the melt but is hard on the kettle.

When melting with oil as a fuel, the oil valve should be set by appearance of flame, not by number on valve. The flame as seen through the hole in the side of the furnace should be orange to yellow, and the flame should appear at the flange of the kettle. This flame at the flange guarantees that the flame is slightly reducing - this means rich and has no free air. Improper mixture will result in a cutting flame.

Alloyed Iron Setting Rings

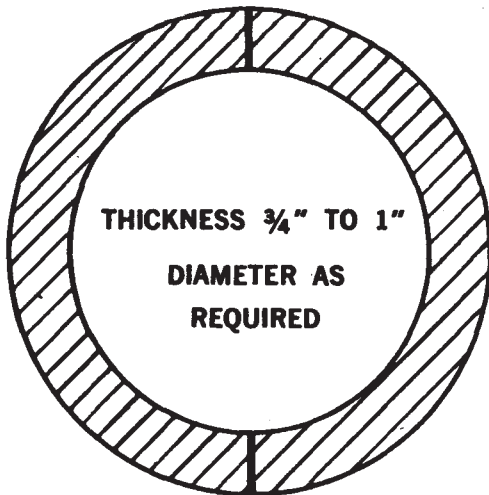
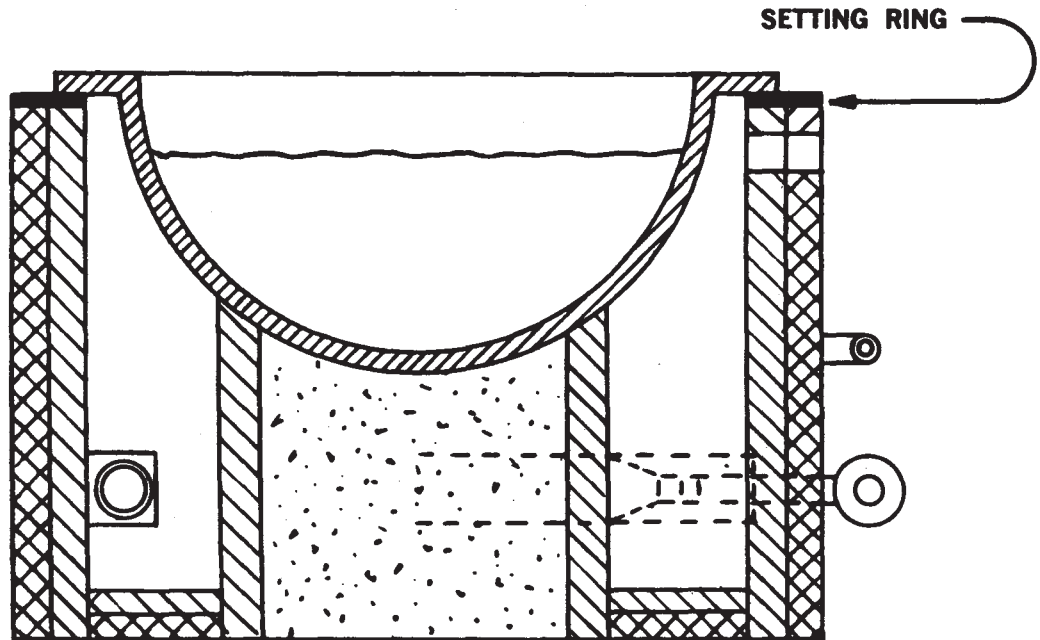

**2 SECTION SETTING RING
FOR SMALL KETTLES**

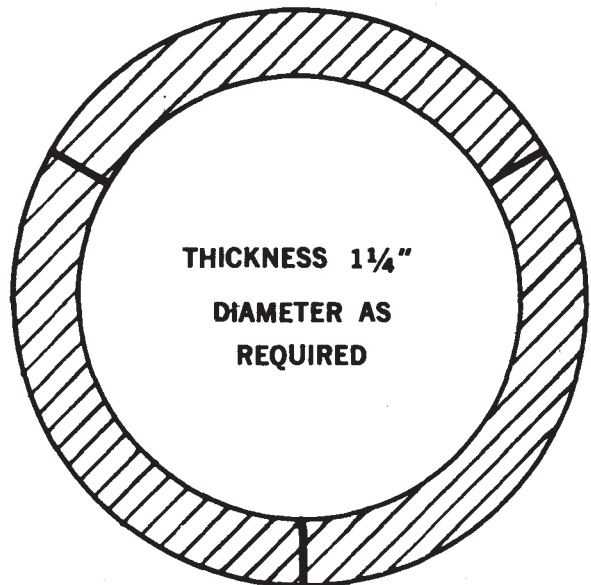

**3 SECTION SETTING RING
FOR LARGE KETTLES**

Bottom Pour Spts

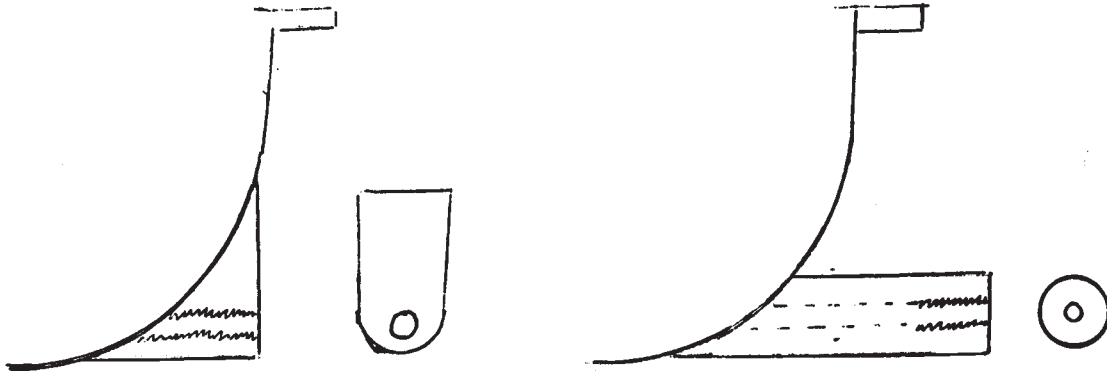

Drilled and tapped to your size.

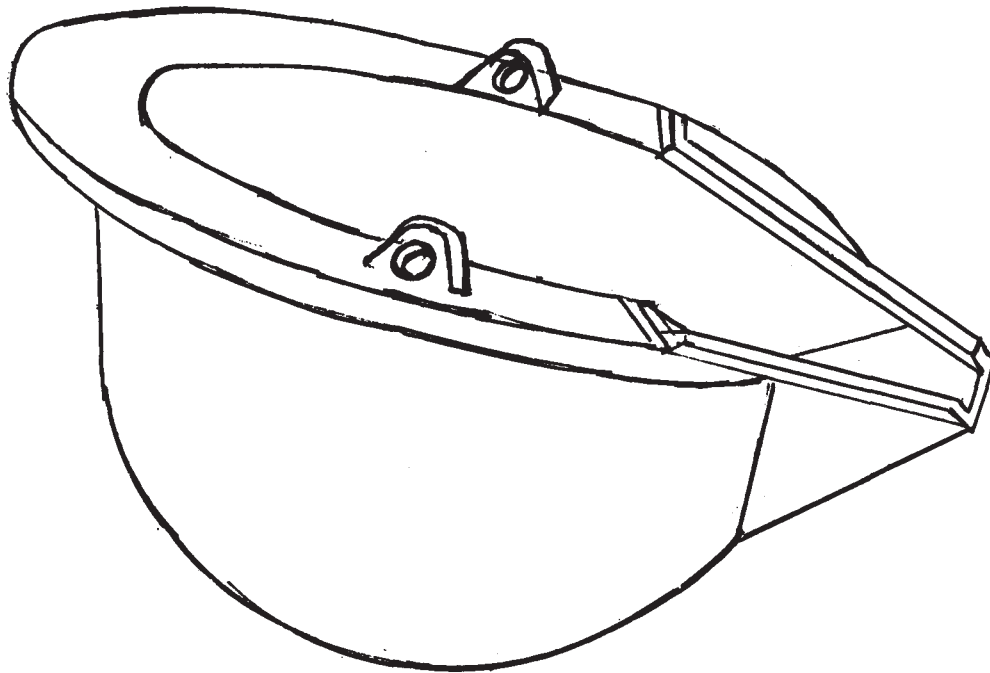

Top Pour Spts. For Tilting Furnaces

Slag Buggy with Cooling Ribs

FOR LARGER VOLUME OF SLAG

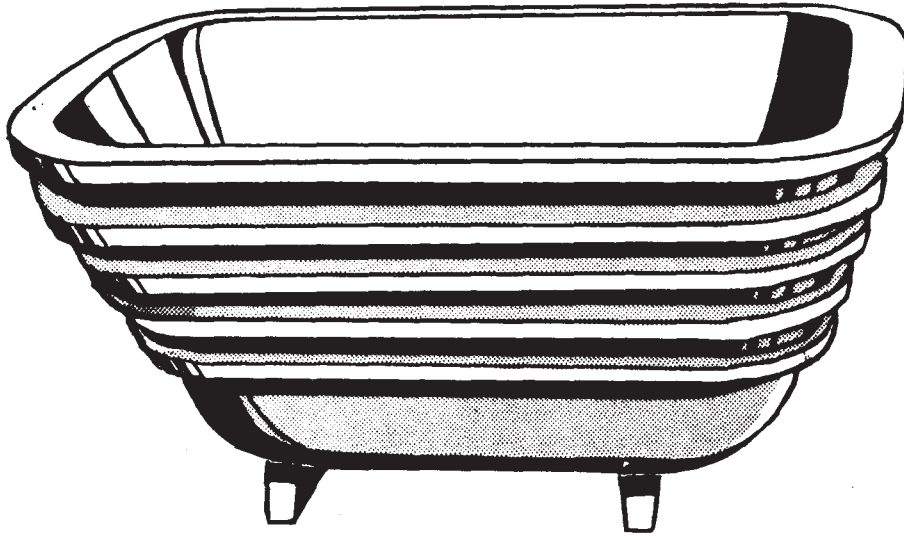

DEPENDING ON METALLIC CONTENT
CAN HOLD FROM 2000# TO 2500# SLAG.

DIMENSIONS

O.D.		I.D.
49 x 36	TOP	43 x 30
	BOTTOM	32 x 18
25"	HEIGHT	20"

APPROXIMATE WEIGHT 2000#.

STOCK — FOR LIFT TRUCK HANDLING.
CAN ALSO BE FURNISHED WITH TRUNIONS FOR HANDLING WITH CRANE.

Rectangular & Round Slag Buggy

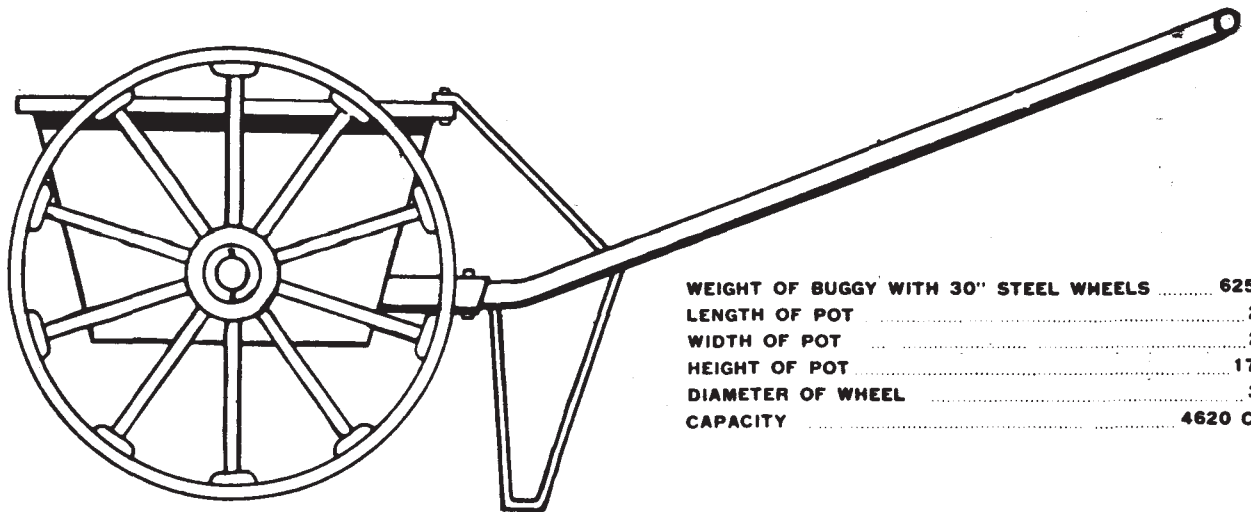

WEIGHT OF BUGGY WITH 30" STEEL WHEELS	625 LBS.
LENGTH OF POT	28 IN.
WIDTH OF POT	20 IN.
HEIGHT OF POT	17½ IN.
DIAMETER OF WHEEL	30 IN.
CAPACITY	4620 CU. IN.

STEEL WHEELS

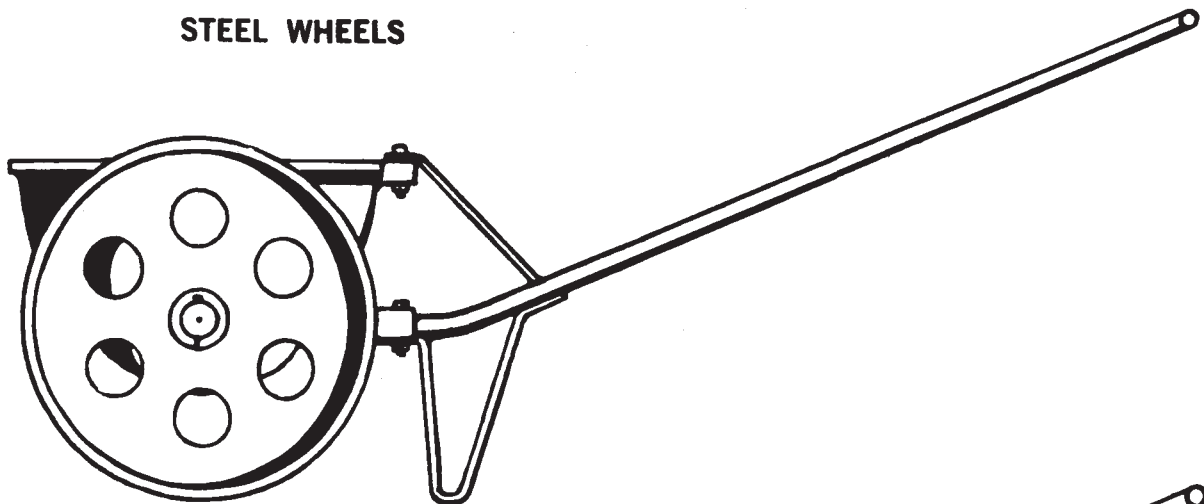

IRON WHEELS

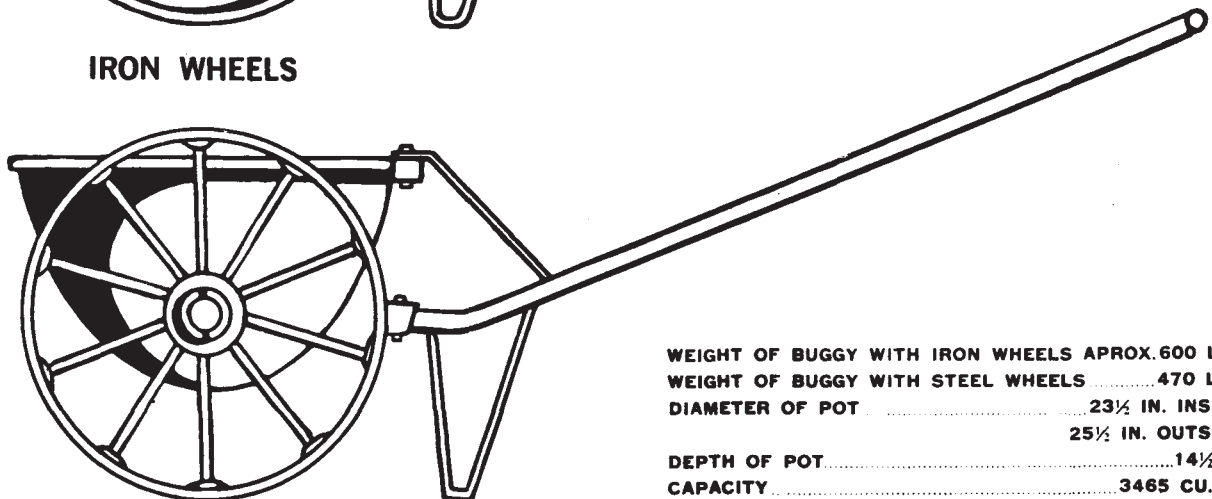

STEEL WHEELS

WEIGHT OF BUGGY WITH IRON WHEELS APROX.	600 LBS.
WEIGHT OF BUGGY WITH STEEL WHEELS	470 LBS.
DIAMETER OF POT	23¼ IN. INSIDE
	25½ IN. OUTSIDE
DEPTH OF POT	14½ IN.
CAPACITY	3465 CU. IN.
DIAMETER OF WHEEL	24¼ IN.
AXLE	1½ IN.

3-LEGGED SLAG BUCKET

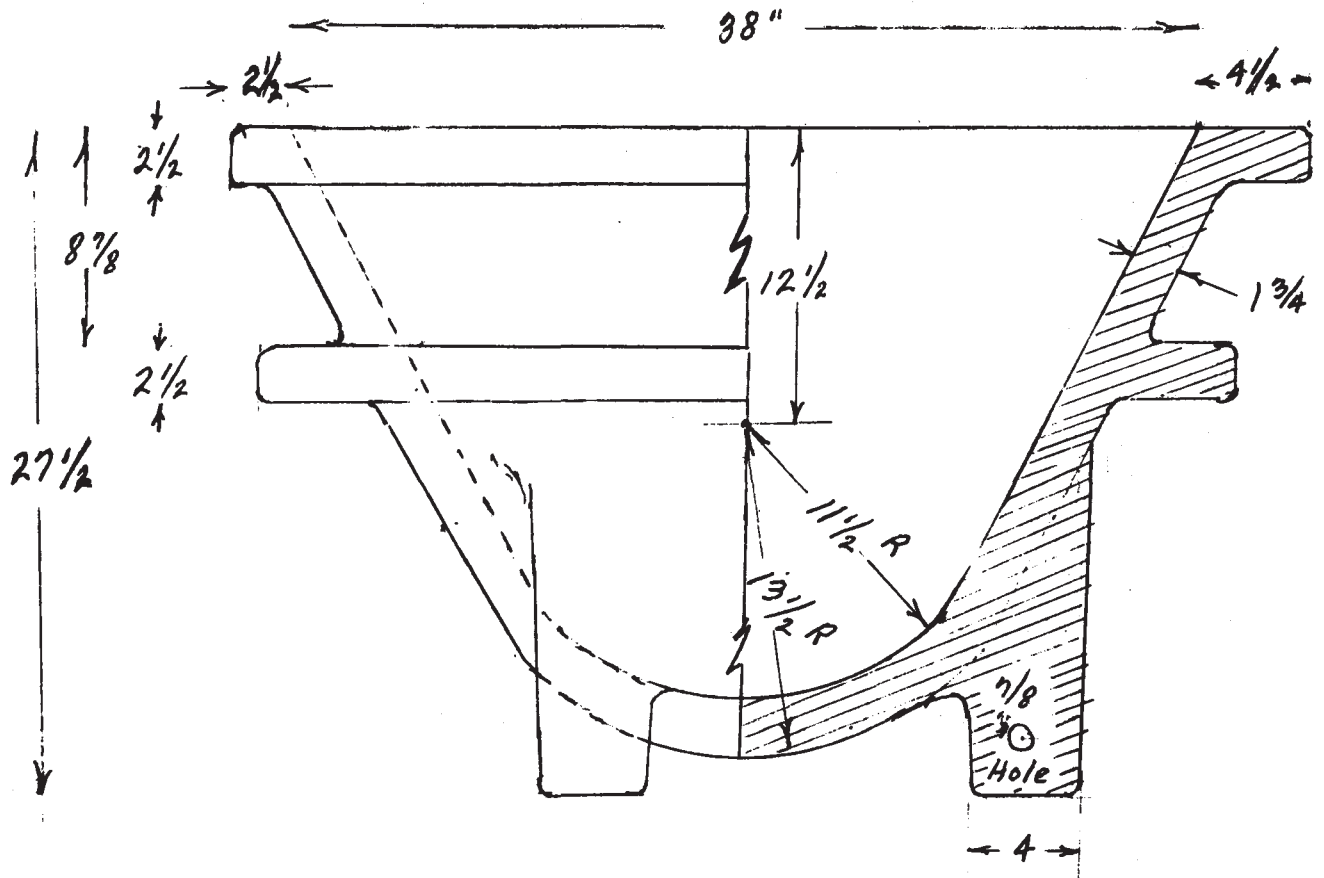

3 Legs
Approximate Capacity 10,800 Cu. In.
Average Weight 1800#

Box Type Slag Pot

Volume 18,000 Cu. In. Average Casting Weight 2400#

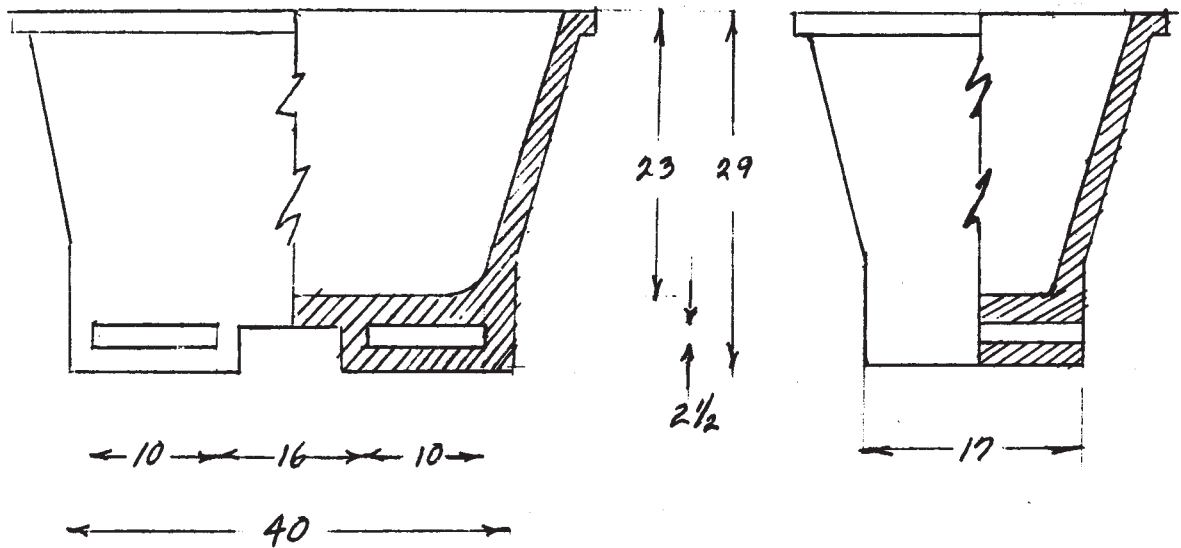
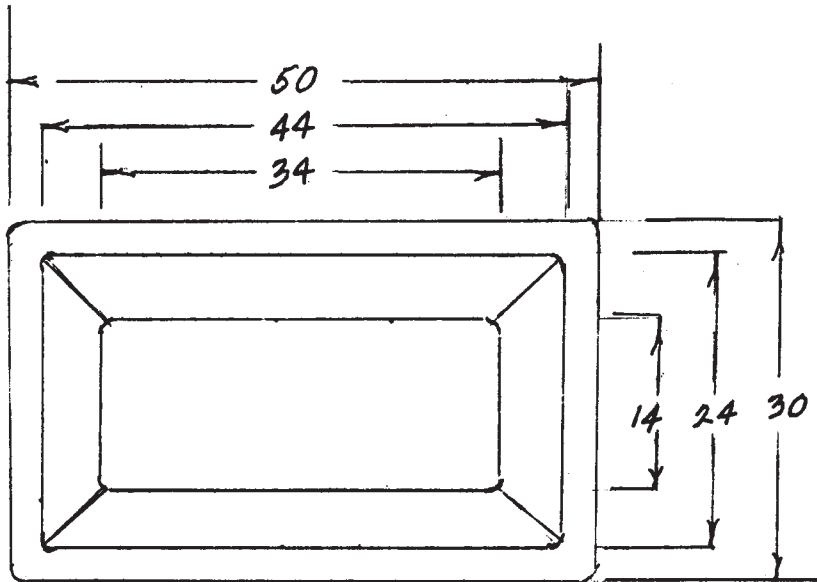

Holding Pots

for Zinc Die Cast Machines

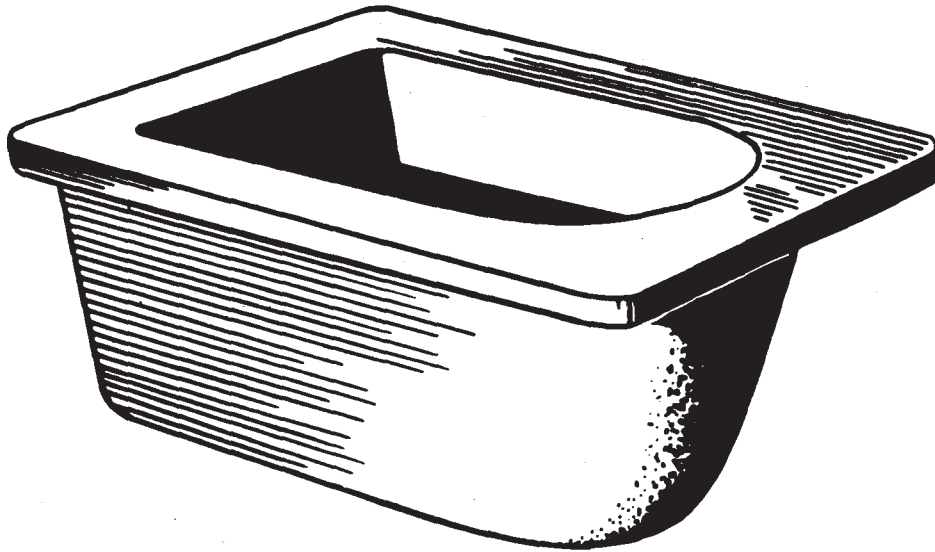

**Ladel Liners and Holding Pots to fit KUX
— CLEVELAND — PRENTICE — B & T —
WORKHORSE — AMERICAN — LAKE ERIE
and Miscellaneous Die Cast Machines**

*OVER 50 VARIETIES OF HOLDING POTS IN STOCK
FOR IMMEDIATE SHIPMENT.*

INDEX

HOLDING POT NO.	PAGE NO.
M-1, M-2, M-3, M-4, M-5	37
M-6, M-7, 40-60 Cleveland	38
7-Z, #50, #200, #400	39
M-B-T ROUND, M-B-T RECTANGULAR, M-B-T #800, 173-T-800	40
R-P-L, R-p-R, R-P-S, R-P-T	41
R-P-W, R-P-1½, R-P-2, S-M	42
T-E-1, T-E-2, V-R-1, XP-101	43
XP-104-S, X-P-104, X-P-105, X-P-106	44
X-P-107, X-P-108, X-P-109, X-P-110	45
X-P110-A, X-P-111, X-P-112,	46
X-P-113, X-P-120, X-P-120-A	47
X-P-120-B, X-P-121	48
BTX, GTX, MCM	49
MBT 100, 12 Ton Hydrocast	50
BWAV 125 & 50 Ton, BWP-301, BWP-300	51
Kemp Holding Pot, DCM	52
CM-1, CM-2	53
400 Ton Cleveland	54

Holding Pots

M-1

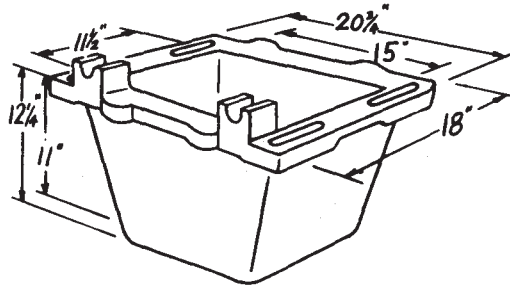

FOR USE IN KUX K-5

ALUMINUM 133#
 DIE CAST 332#
 CUBIC INCHES 1386
 APPROXIMATE WEIGHT OF
 POT 190 LBS.

M-2

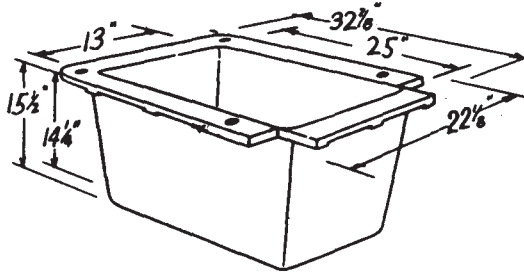

**FOR USE IN
 KUX CS-144, BA-BH-12**

ALUMINUM 333#
 DIE CAST 831#
 APPROXIMATE WEIGHT OF
 POT 495 LBS.

M-3

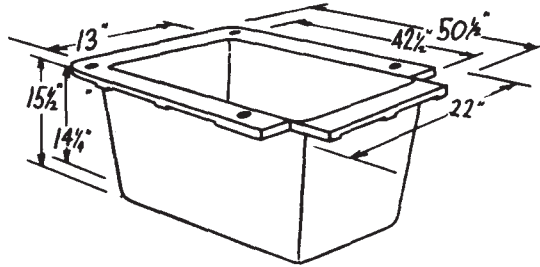

FOR USE IN KUX BH-40

ALUMINUM 622#
 DIE CAST 1552#
 CUBIC INCHES 3415
 APPROXIMATE WEIGHT OF
 POT 742 LBS.

M-4

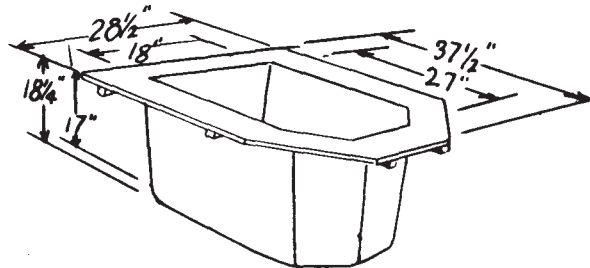

**FOR USE IN
 KUX BH-7 & 37**

ALUMINUM 556#
 DIE CAST 1386#
 CUBIC INCHES 5560
 APPROXIMATE WEIGHT OF
 POT 775 LBS.

M-5

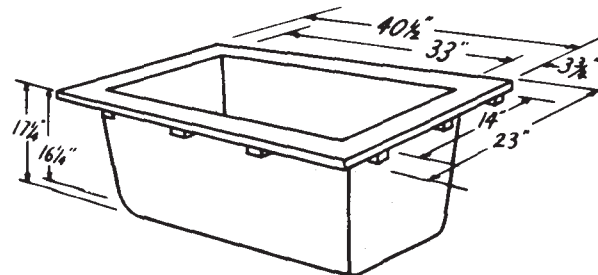

FOR USE IN KUX 400

APPROXIMATE WEIGHT OF
 POT 660 LBS.

Holding Pots

M-6

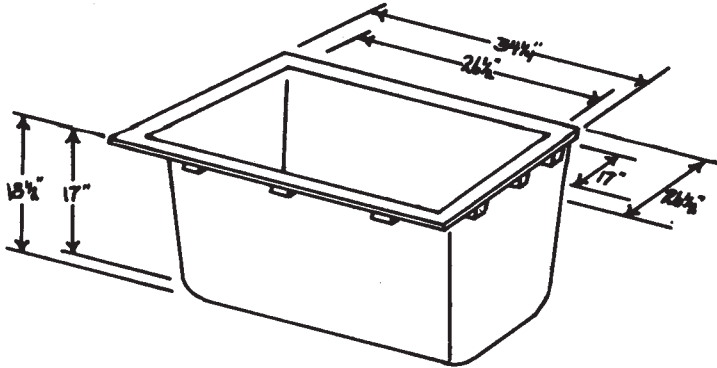

FOR USE IN A
KUX 200
APPROXIMATE WEIGHT OF
POT 550 LBS.

M-7

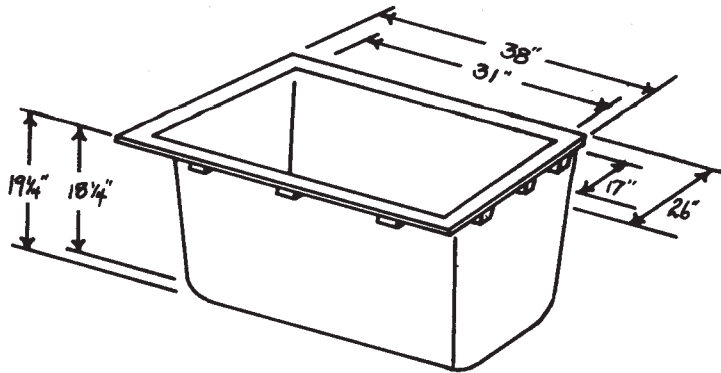

FOR USE IN
KUX 425
APPROXIMATE WEIGHT OF
POT 696 LBS.

40-60
Cleveland

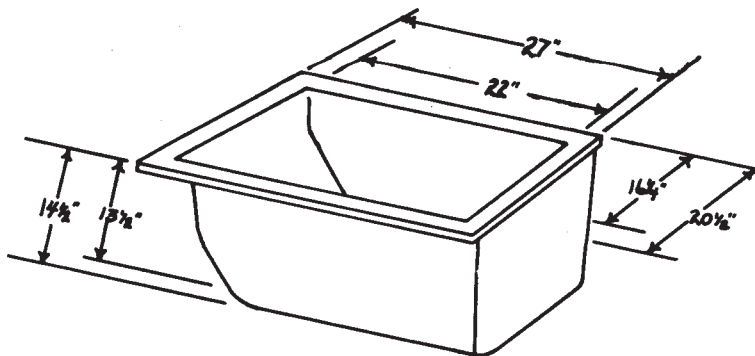

FOR USE IN A
40-60 CLEVELAND
APPROXIMATE WEIGHT OF
POT 220 LBS.

holding pots

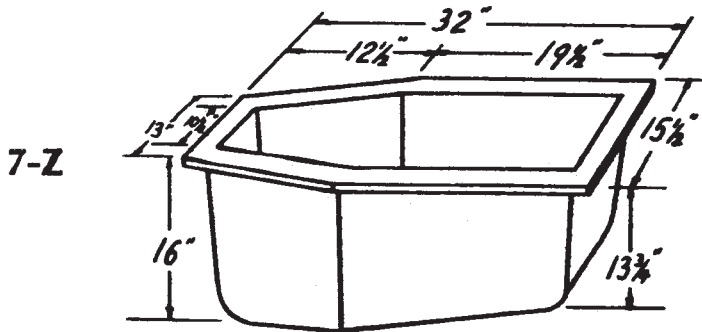

**FOR USE IN
CAST MASTER 100 TON**
APPROXIMATE WEIGHT OF
POT 385 LBS.

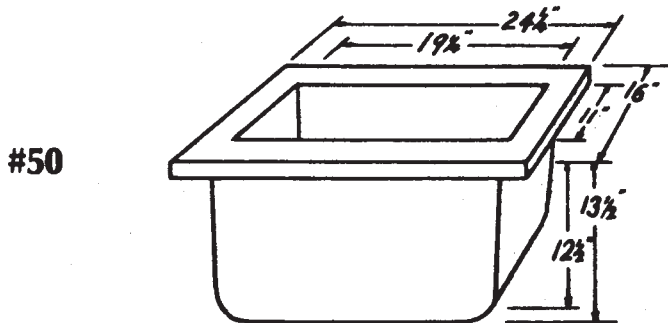

**FOR USE IN
CLEVELAND 50**
APPROXIMATE WEIGHT OF
POT 280 LBS.

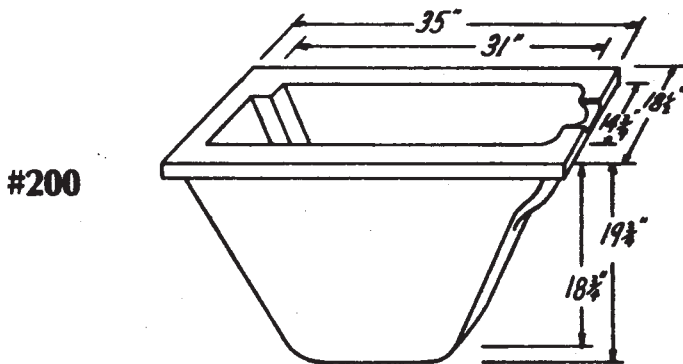

**FOR USE IN
CLEVELAND 200**
APPROXIMATE WEIGHT OF
POT 525 LBS.

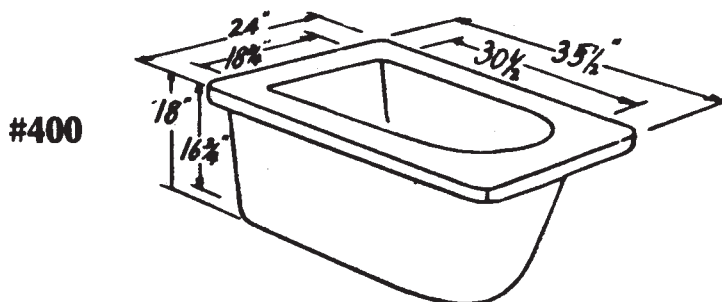

**FOR USE IN
CLEVELAND 400**
ALUMINUM 556#
DIE CAST 1386#
CUBIC INCHES 5775
APPROXIMATE WEIGHT OF
POT 580 LBS.

Holding Pots

**M-B-T
Round**

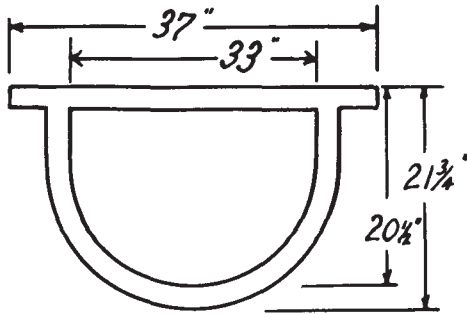

FOR USE IN B&T
 ALUMINUM..... 1156#
 DIE CAST..... 2882#
 APPROXIMATE WEIGHT OF
 POT 585 LBS.

**M-B-T
Rectangular**

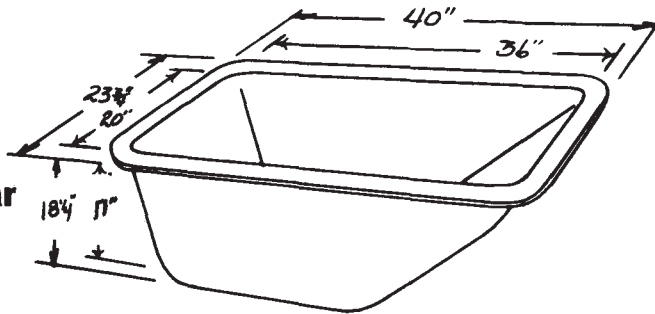

**FOR USE IN
B&T 400, 250 & 200**
 ALUMINUM..... 823#
 DIE CAST..... 2051#
 APPROXIMATE WEIGHT OF
 POT 785 LBS.

**M-B-T
#800**

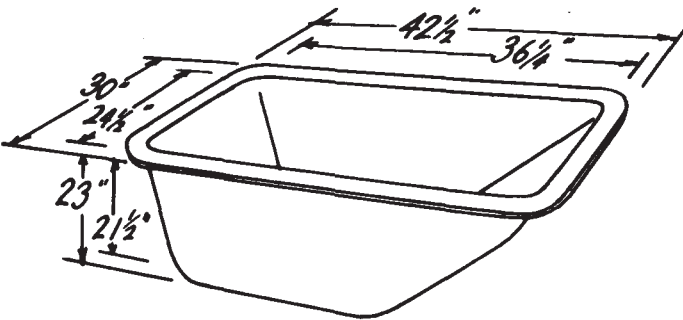

**FOR USE IN
B&T 600 & 800**
 APPROXIMATE WEIGHT OF
 POT 935 LBS.

**M-B-T
800 HVY.**

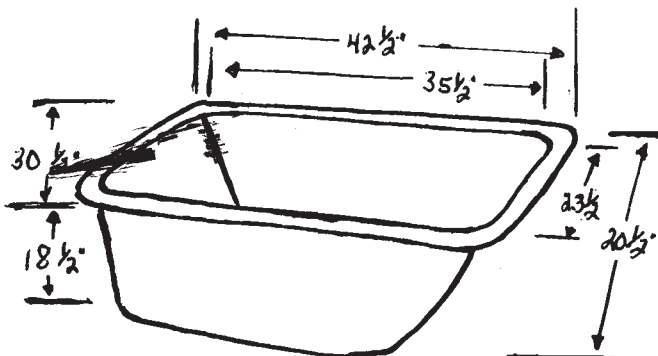

**FOR USE IN
B & T 600 & 800**
 APPROXIMATE WEIGHT OF
 POT..... 1140 LBS.

Holding Pots

R-P-L

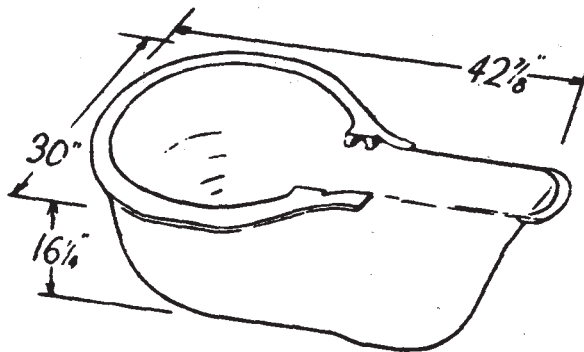

**FOR USE IN
REED-PRENTICE**

ALUMINUM 467#
DIE CAST 1164#
APPROXIMATE WEIGHT OF
POT 610 LBS.

R-P-R

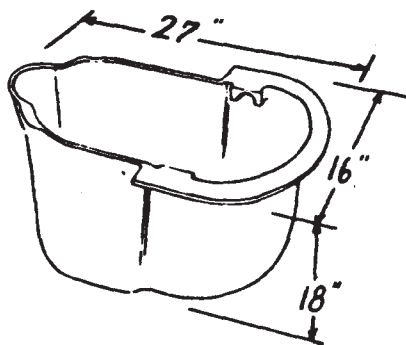

**FOR USE IN
REED-PRENTICE**

ALUMINUM 289#
DIE CAST 720#
APPROXIMATE WEIGHT OF
POT 306 LBS.

R-P-S

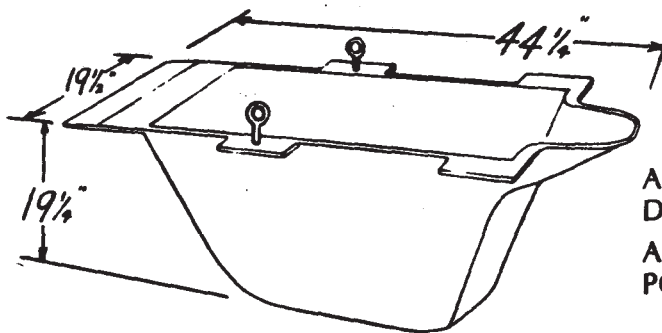

**FOR USE IN
REED-PRENTICE 1 1/2**

ALUMINUM 489#
DIE CAST 1219#
APPROXIMATE WEIGHT OF
POT 495 LBS.

R-P-T

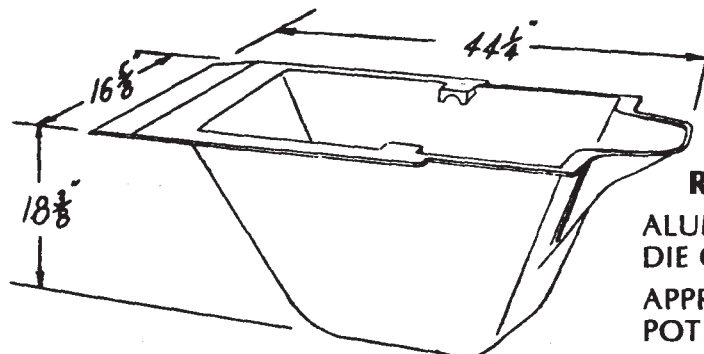

**FOR USE IN
REED-PRENTICE 1 1/2**

ALUMINUM 415#
DIE CAST 998#
APPROXIMATE WEIGHT OF
POT 540 LBS.

Holding Pots

R-P-W

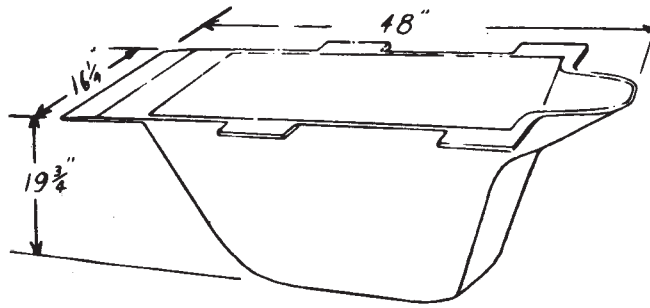

**FOR USE IN
REED-PRENTICE**

ALUMINUM 600#
DIE CAST 1496#
CUBIC INCHES 6237
APPROXIMATE WEIGHT OF
POT 600 LBS.

R-P 1½

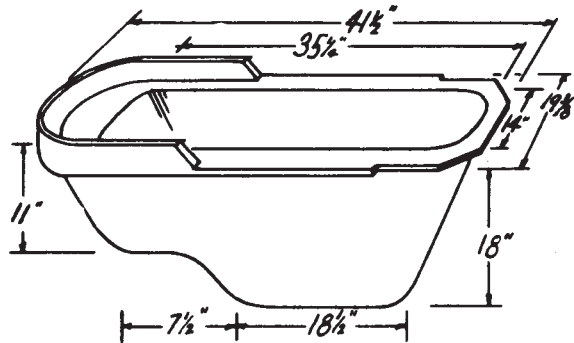

**FOR USE IN
REED-PRENTICE
VACUUM 1½**

APPROXIMATE WEIGHT OF
POT 635 LBS.

R-P 2

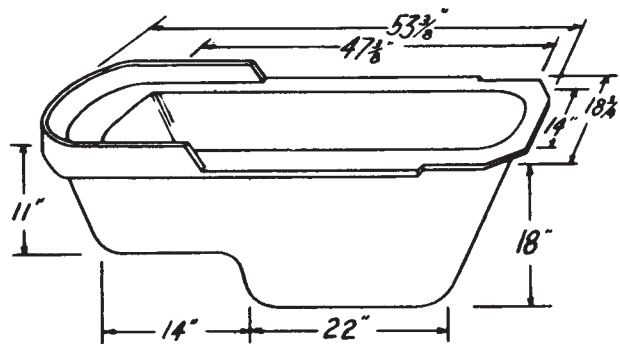

**FOR USE IN
REED-PRENTICE
VACUUM 2**

APPROXIMATE WEIGHT OF
POT 650 LBS.

S-M

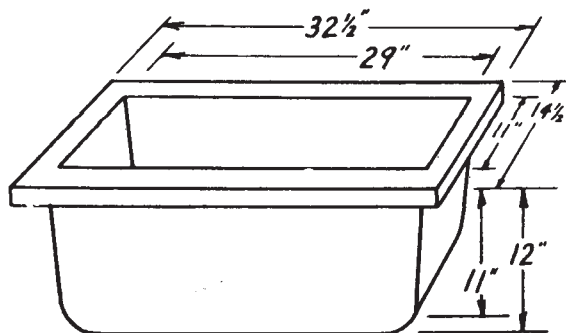

**FOR USE IN
WORKHORSE**

ALUMINUM 222#
DIE CAST 554#
CUBIC INCHES 2310
APPROXIMATE WEIGHT OF
POT 210 LBS.

Ladel Liners and Holding Pots

T-E 1

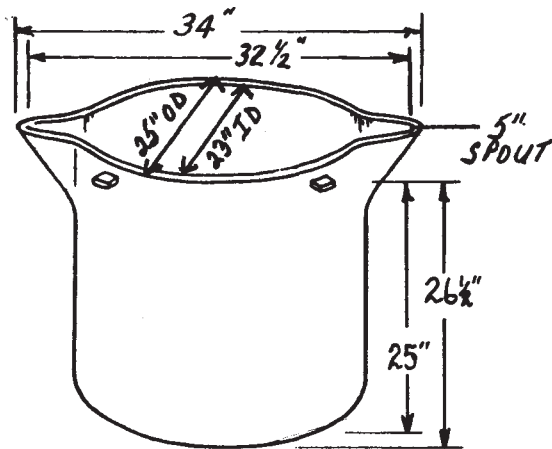

ZINC 2160#
 ALUMINUM 784#
 DIE CAST 1885#
 CUBIC INCHES 7854
 APPROXIMATE WEIGHT OF
 POT 710 LBS.

T-E 2

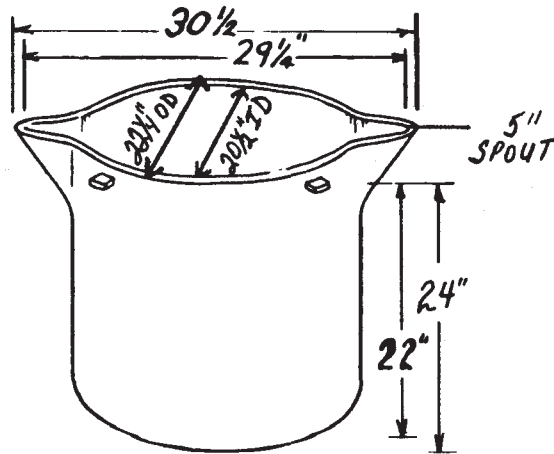

ZINC 1458#
 ALUMINUM 577#
 DIE CAST 1386#
 CUBIC INCHES 5775
 APPROXIMATE WEIGHT OF
 POT 375 LBS.

V-R 1

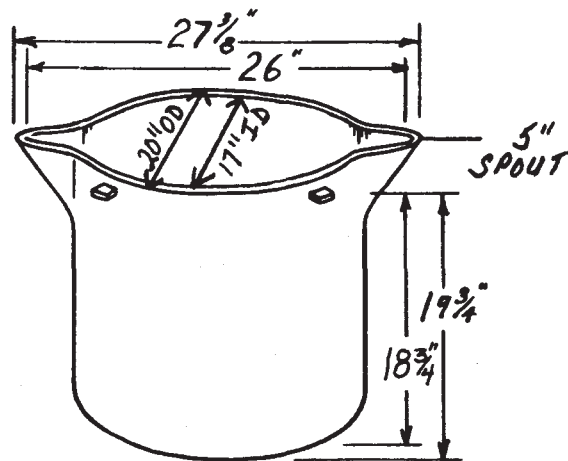

ZINC 875#
 ALUMINUM 346#
 DIE CAST 831#
 CUBIC INCHES 3460
 APPROXIMATE WEIGHT OF
 POT 346 LBS.

X-P 101

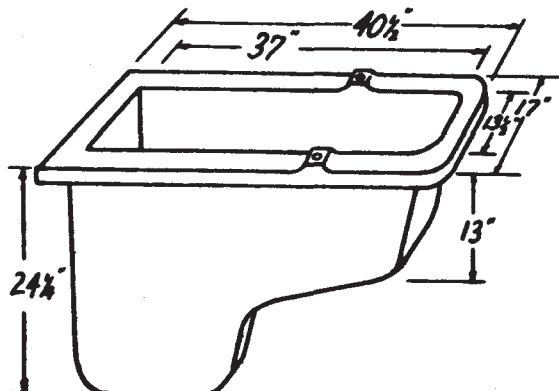

**FOR USE IN
 CAST MASTER**
 APPROXIMATE WEIGHT OF
 POT 610 LBS.

Holding Pots

X-P 104-S

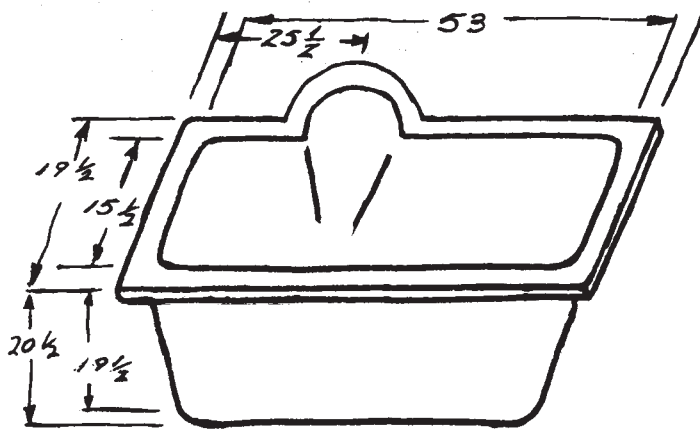

**FOR USE IN A
CASTMASTER
XP-104S**

X-P 104

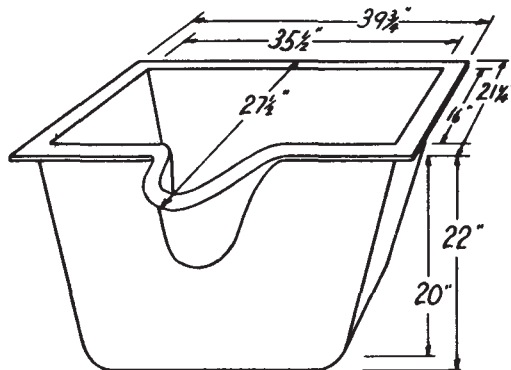

**FOR USE IN
CAST MASTER**
APPROXIMATE WEIGHT OF
POT 654 LBS.

X-P 105

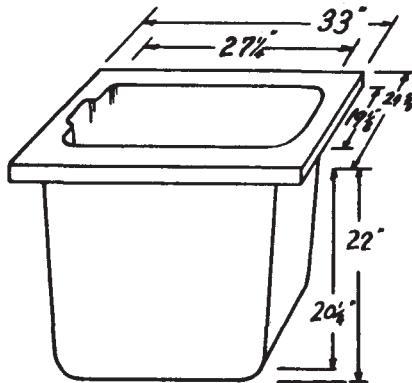

**FOR USE IN
CAST MASTER**
APPROXIMATE WEIGHT OF
POT 870 LBS.

X-P 106

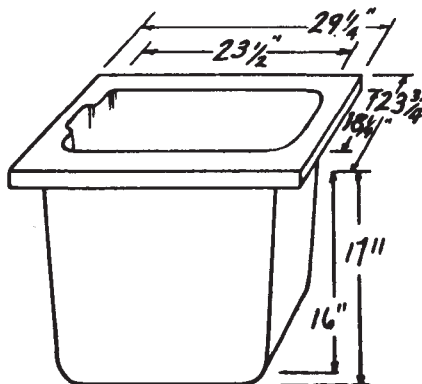

**FOR USE IN
CAST MASTER**
APPROXIMATE WEIGHT OF
POT 574 LBS.

Holding Pots

X-P 107

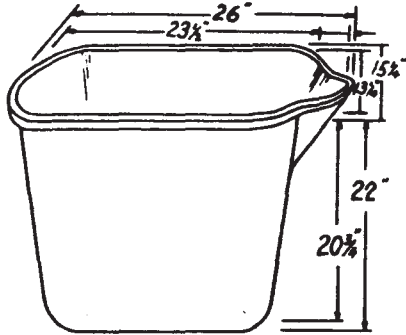

FOR USE IN B&T
 APPROXIMATE WEIGHT OF
 POT 250 LBS.

X-P 108

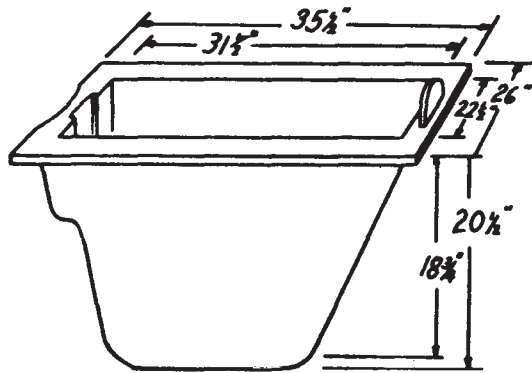

FOR USE IN CLEVELAND
 APPROXIMATE WEIGHT OF
 POT 694 LBS.

X-P 109

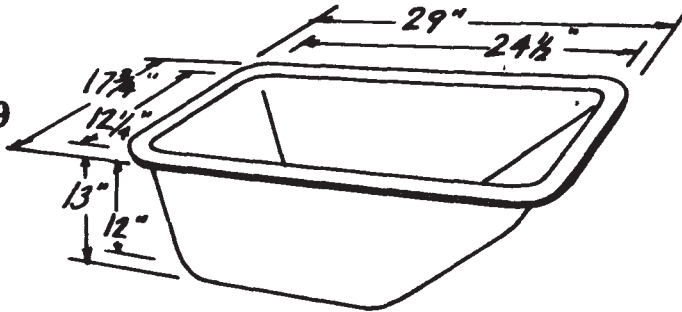

FOR USE IN AMERICAN DIE 60 TON
 APPROXIMATE WEIGHT OF
 POT 190LBS.

X-P 110

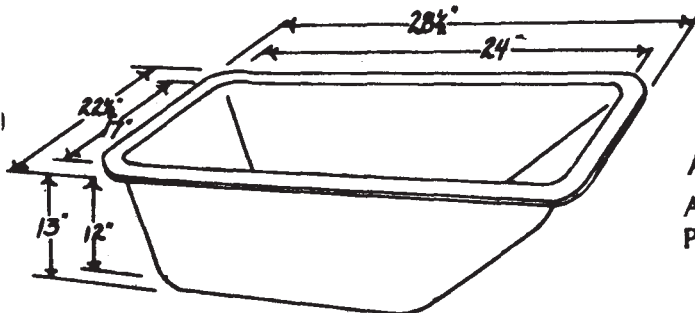

FOR USE IN AMERICAN DIE 150 TON
 APPROXIMATE WEIGHT OF
 POT 265LBS.

Holding Pots

X-P 110A

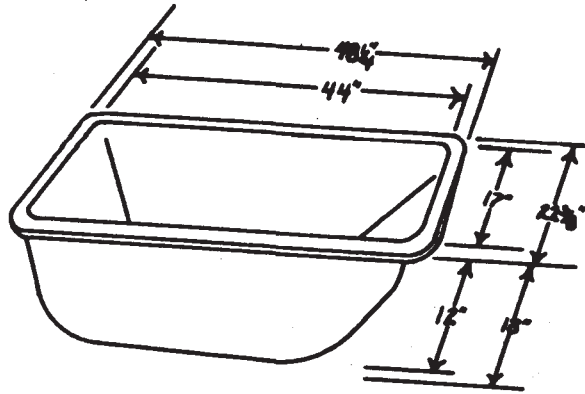

**FOR USE IN
AMERICAN 150 HEAVY**
APPROXIMATE WEIGHT OF
POT..... 456 LBS.

X-P 111

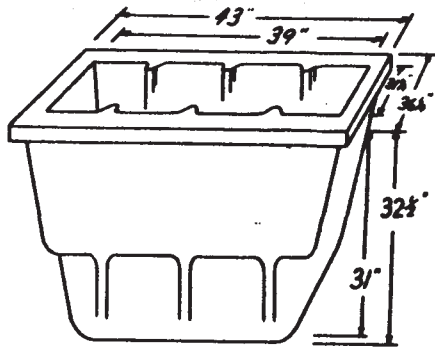

**FOR USE IN
CAST MASTER**
APPROXIMATE WEIGHT OF
POT 1680 LBS.

X-P 112

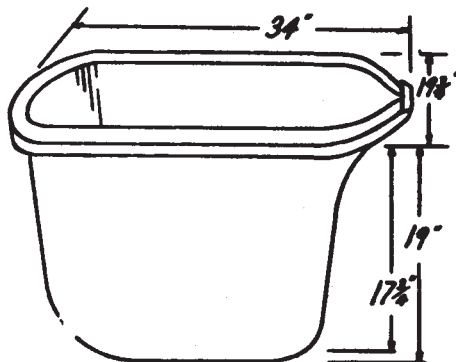

**FOR USE IN A
LAKE ERIE 250 TON**
APPROXIMATE WEIGHT OF
POT 350 LBS.

Holding Pots

X-P 113

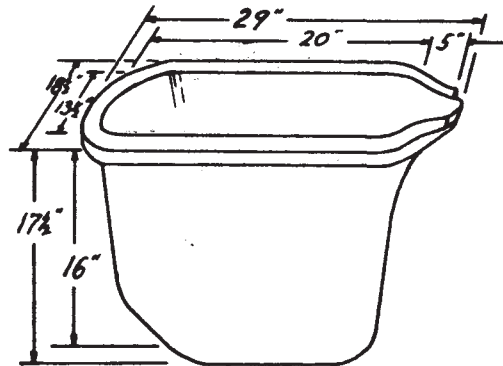

**FOR USE IN A
SCHULTZ**

APPROXIMATE WEIGHT OF
POT 362 LBS.

X-P 120

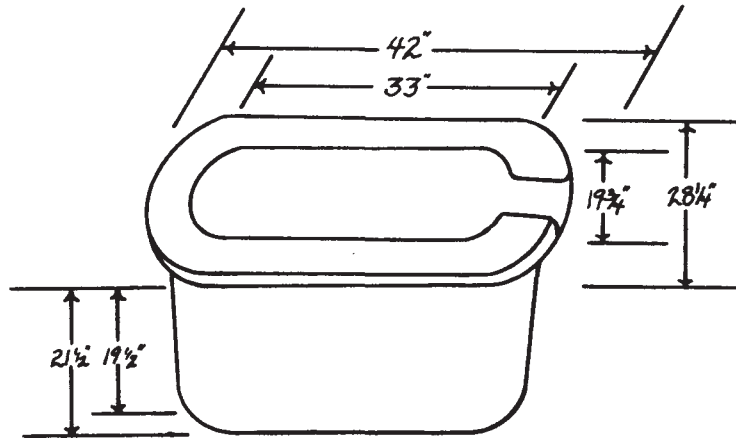

**FOR USE IN
LESTER PHOENIX
#17020**

APPROXIMATE WEIGHT OF
POT..... 935 LBS.

X-P 120A

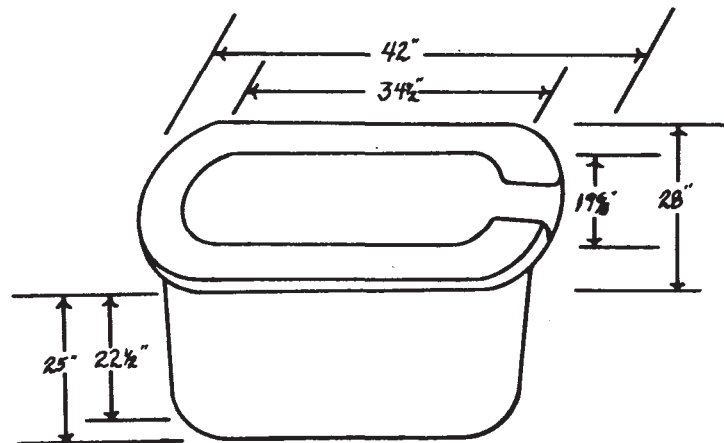

**FOR USE IN
LESTER PHOENIX
400 TON**

APPROXIMATE WEIGHT OF
POT..... 1170 LBS.

Holding Pots

X-P 120B

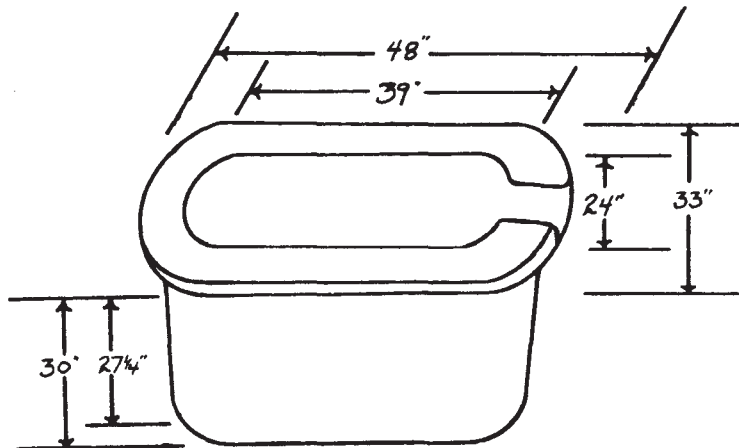

**FOR USE IN
LESTER PHOENIX
600 TON**

APPROXIMATE WEIGHT OF
POT..... 1558 LBS.

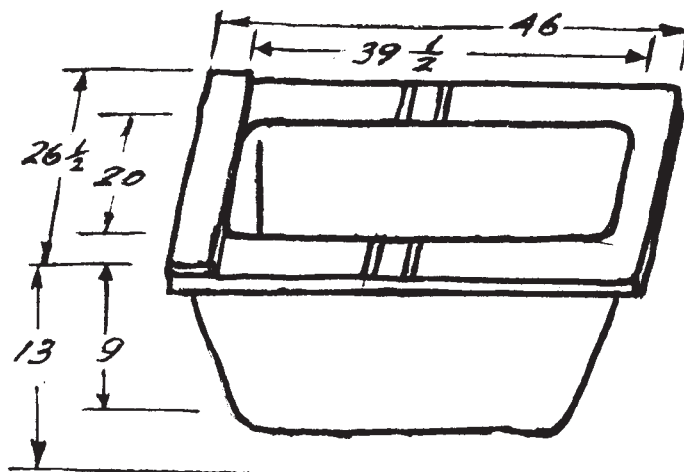

**Z-1000
AVNET**

APPROXIMATE WEIGHT OF
POT 460 LBS.

X-P 121

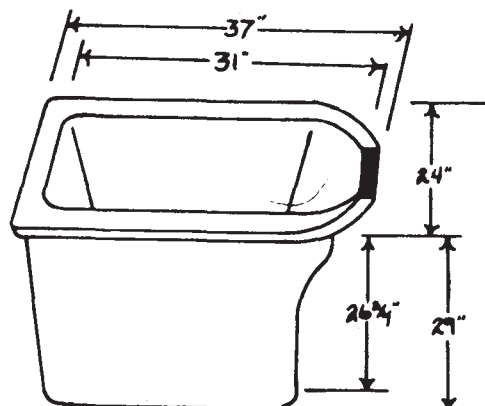

**FOR USE IN
LAKE ERIE 600 TON**

APPROXIMATE WEIGHT OF
POT..... 1054 LBS.

BTX

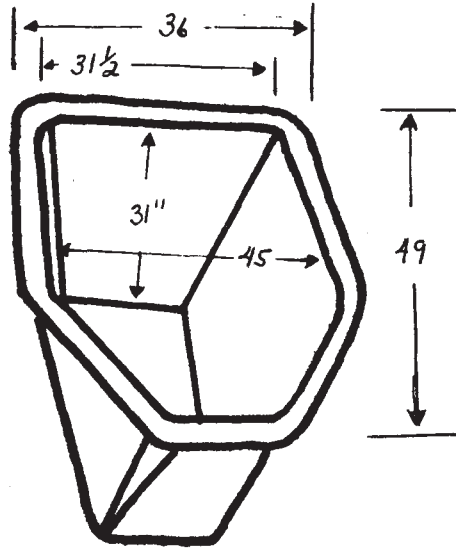

**FOR USE IN A
B & T MACHINE**
APPROXIMATE WEIGHT OF
POT..... 1584 LBS.

GTX

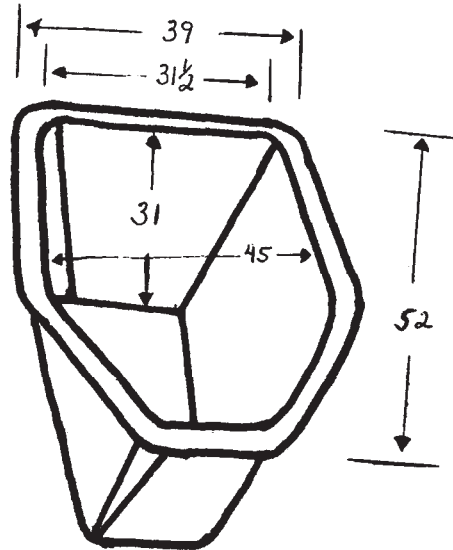

**FOR USE IN A
B & T MACHINE**
APPROXIMATE WEIGHT OF
POT..... 1600 LBS.

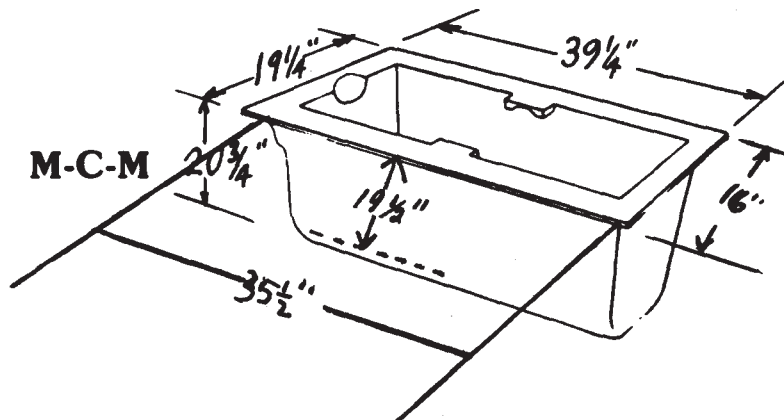

FOR USE IN CAST MASTER
1 oz. & 2 oz 250 & 500
1000 TON

ALUMINUM..... 600#
DIE CAST..... 1496#
APPROXIMATE WEIGHT OF
POT..... 600 LBS.

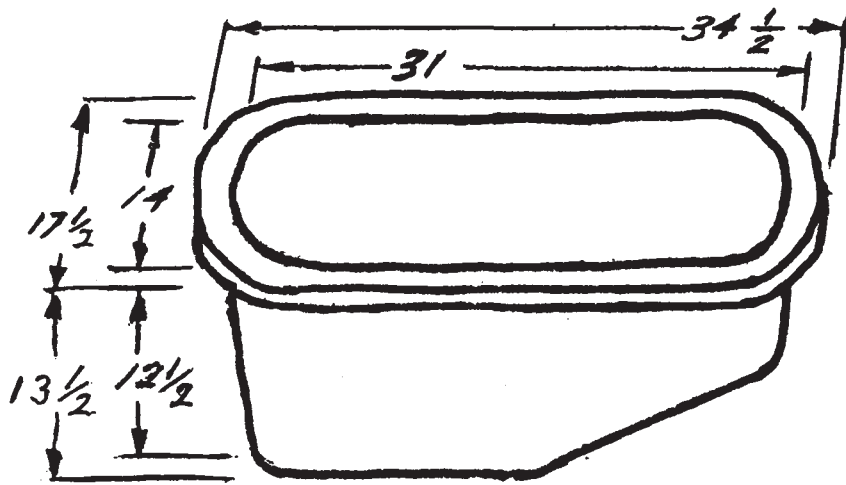

**FOR USE IN
B & T 100 TON**

M-B-T-100

FOR USE IN A 12 TON HYDRACAST DIE CAST MACHINE

APPROXIMATE WEIGHT 218 LBS.

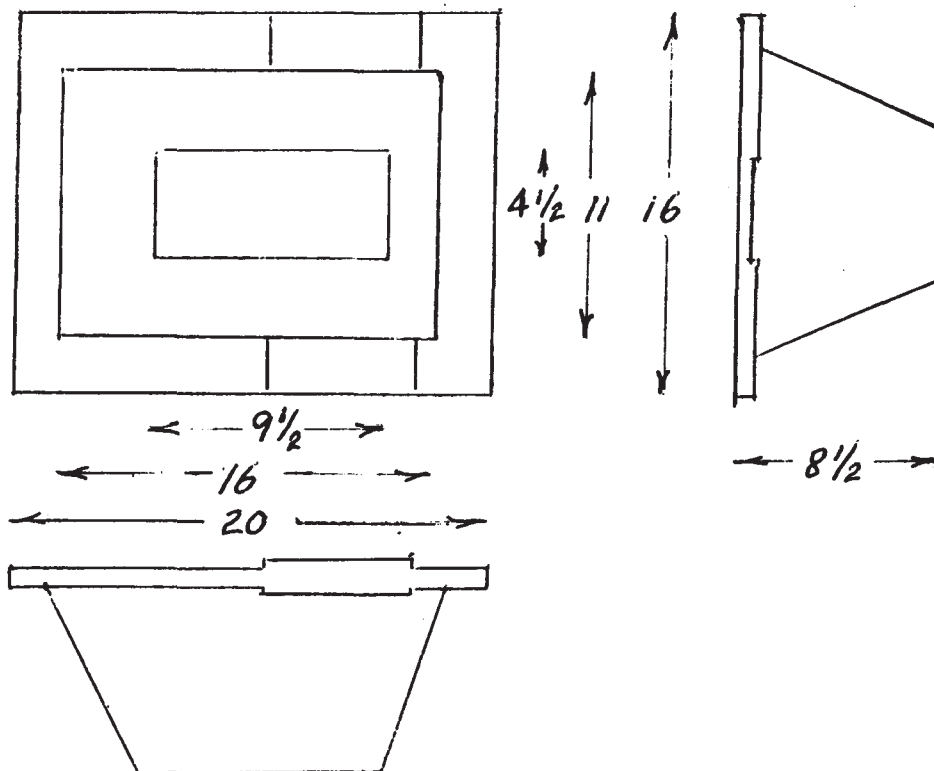

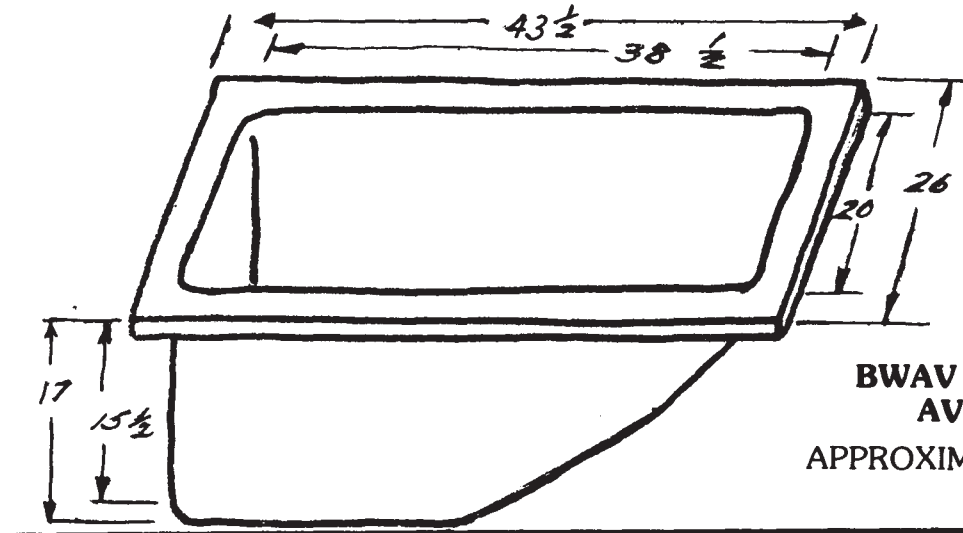

**BWAV 125 TON & 50 TON
AVNET MACHINE**
APPROXIMATE WEIGHT 940 LBS.

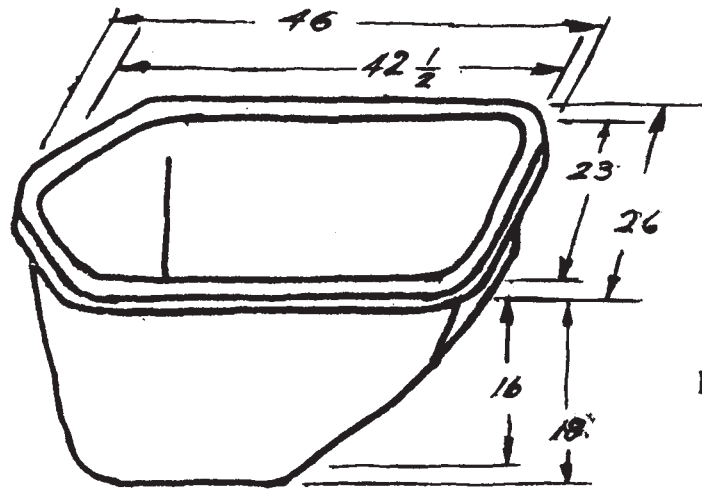

BWP-301 600 TON PRINCE

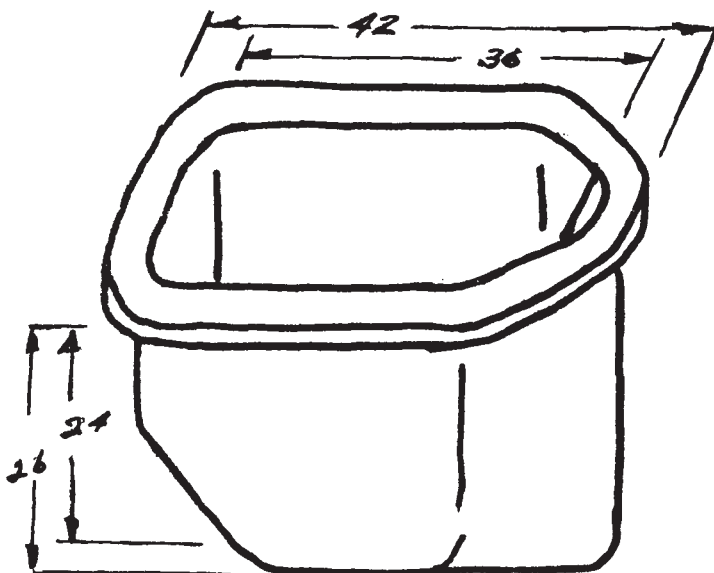

**BWP-300
PRINCE MACHINE**

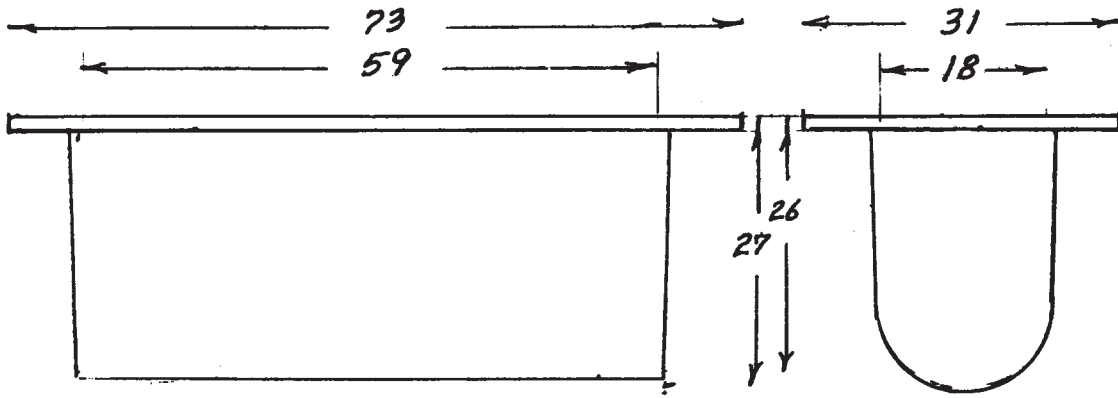

FOR USE IN KEMP HOLDING FURNACE
 APPROXIMATE WEIGHT 1900 LBS.

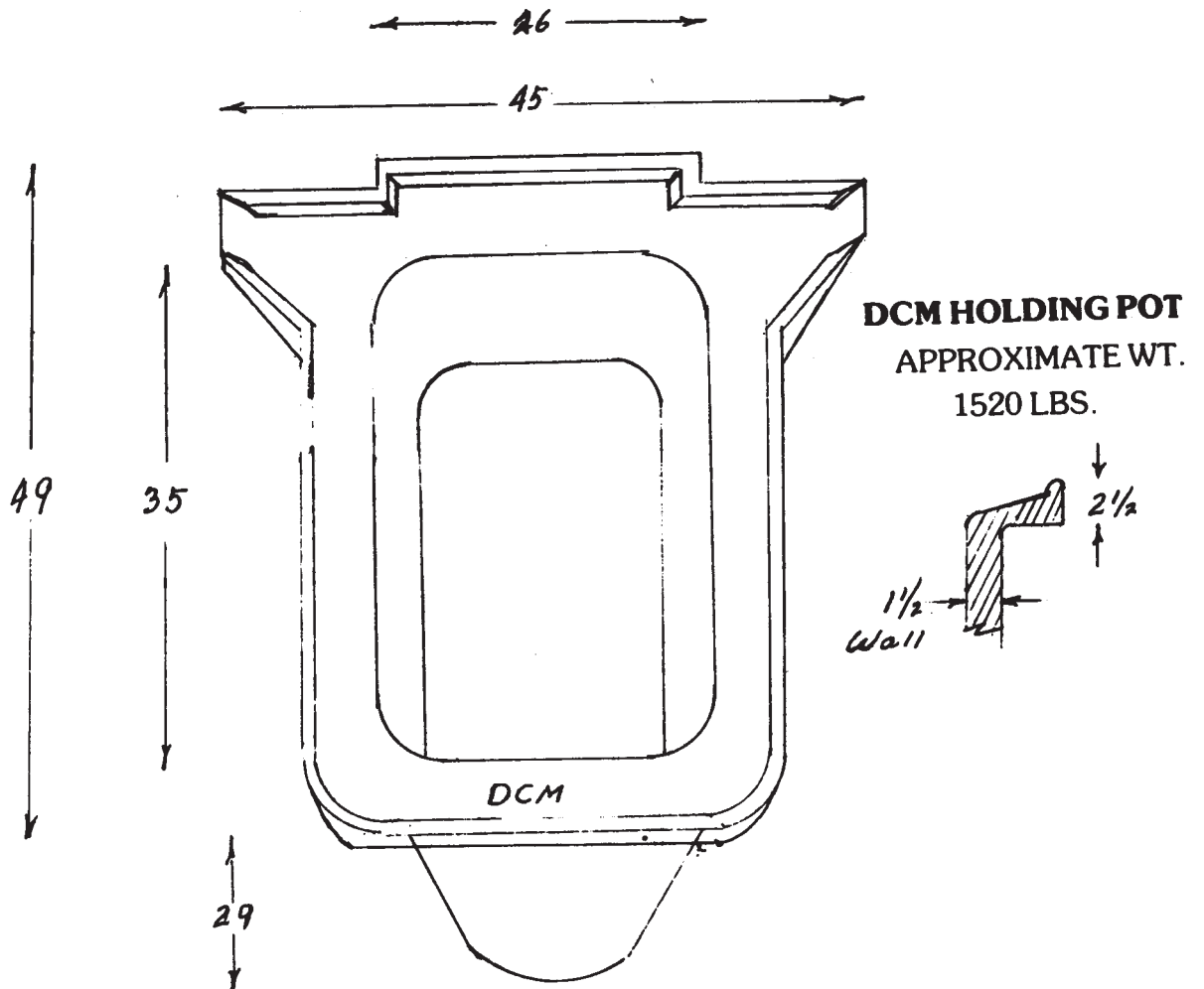

CM-1

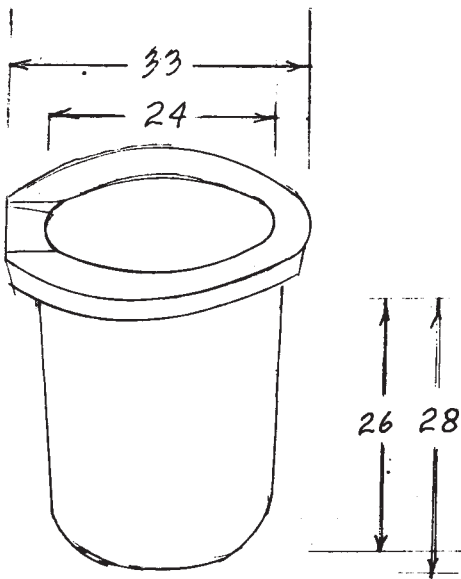

CM-2

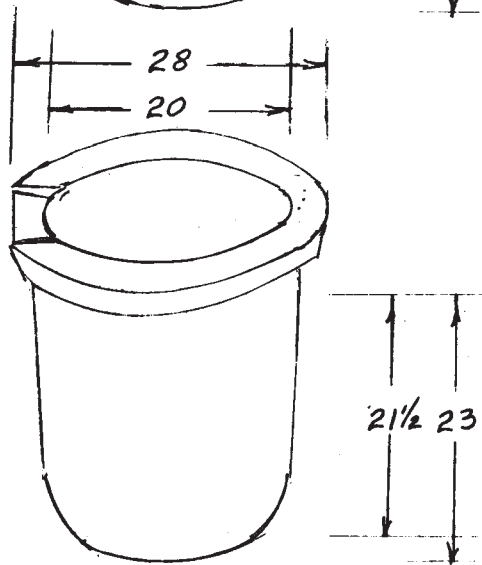

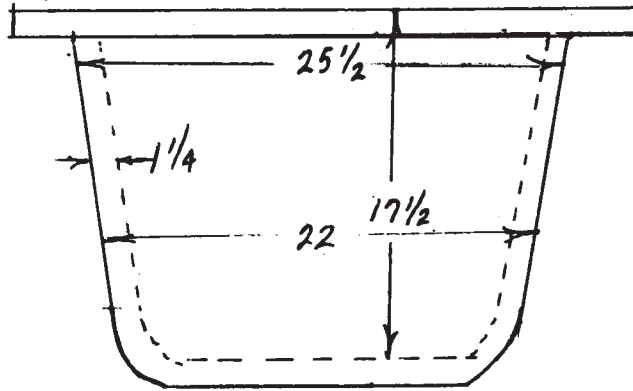

**FOR USE IN
A 400 TON
CLEVELAND**

APPROXIMATE WEIGHT OF
POT..... 920 LBS.

